

Cat. No. Y108-E1-1

Solid State Relay User's Guide

OMRON

Introduction

SSR stands for Solid State Relay. First marketed in the 1970's, SSRs have recently become very popular for the following reasons.

- As a means of creating no-contact relays in output power sections accompanying conversion of control circuits to ICs.
- As a means of increasing service life and reducing maintenance.
- As a means of preventing operating errors caused through noise by isolating signal circuits and outputs.
- As a means of reducing the clicking sounds produced when load currents turn ON.

In these and other ways, SSRs have proven to provide many special characteristics to meet market needs, and OMRON SSRs have been developed in product series to meet the needs of our customers.

This guidebook has been produced in response to demand from customers to provide the product and technical information required to select the best SSRs according to purpose and application. In this, we hope that this guidebook is helpful to you in applying OMRON SSRs.

OMRON constantly works to increase the quality and reliability of our products. In SSRs, however, we use semiconductors, which are generally known to malfunction or fail from time to time. When applying SSRs, consider all required safety measures, such as redundant designs, measures to prevent the spread of fire, and measures for malfunctions, to protect against personal damage, fire, or public damage that might result from the failure of an SSR.

1 Basic Concepts of SSRs	8
1-1 What Are SSRs?.....	8
(1) Difference between SSRs and Mechanical Relays	
(2) Control of SSRs (ON/OFF Control, Cycle Control, Phase Control)	
(3) Configuration and Operating Principle of MOS FET Relays	
(4) SSR Application Examples	
(5) SSR Classifications	
(6) SSR Glossary	
2 Designing SSR Circuits	14
2-1 Input Circuit.....	14
(1) Input Noise	
(2) Input Conditions	
2-2 Output Circuit.....	16
(1) AC ON/OFF SSR Output Noise Surges	
(2) DC ON/OFF SSR Output Noise Surges	
(3) AND Circuits with DC Output SSRs	
(4) Self-holding Circuits	
(5) Selecting an SSR with Differing Loads	
(6) Inrush Currents to Transformer Loads	
(7) Transformer Tap Selection	
(8) Controlling Power for Transformer Loads	
2-3 Load Power Supply.....	21
(1) Rectified Currents	
(2) Operating Frequency for AC Load Power Supply	
(3) Low AC Voltage Loads	
(4) Phase-controlled AC Power Supplies	
2-4 Application Circuit Examples.....	22
(1) Connection to Sensor	
(2) Switching Control of Incandescent Lamp	
(3) Temperature Control of Electric Furnace	
(4) Forward and Reverse Operation of Single-phase Motor	
(5) ON/OFF Control of Three-phase Inductive Motor	
(6) Forward and Reverse Operation of Three-phase Motor	
(7) Forward/Reverse Rotation: Example 1	
2-5 Fail-safe Concept.....	27
(1) Error Mode	
(2) Short-circuit Protection (Fuse Selection) and Overcurrent Protection	
(3) Operation Indicator	

2-6	Heat Radiation Designing	28
	(1) SSR Heat Radiation	
	(2) Heat Sink Selection	
	(3) Calculating Heat Sink Area	
	(4) Control Panel Heat Radiation Designing	
	(5) Types of Cooling Device	
3	Mounting and Installation	30
3-1	Operation	30
	(1) Leakage Current	
	(2) Screw Tightening Torque	
	(3) SSR Mounting Panel Quality and Tightening Torque	
	(4) Surface-mounting Socket	
	(5) SSR Mounting and Dismounting Direction	
	(6) Wiring for Wrapping Terminal Socket	
	(7) Tab Terminal Soldering Precautions	
	(8) Cutting Terminals	
	(9) Deformed Terminals	
	(10) Hold-down Clips	
	(11) Ultrasonic Cleaning	
	(12) Terminal Arrangements and Internal Connections	
3-2	Panel Mounting	32
	(1) SSR Mounting Pitch	
	(2) Relationship between SSRs and Ducts	
	(3) Ventilation	
	(4) Confirmation after Installation	
3-3	Operation and Storage Environment Precautions	34
	(1) Ambient Temperature (Operating)	
	(2) Operation and Storage Locations	
	(3) Extended Storage of the SSR	
	(4) Vibration and Shock	
	(5) Solvents	
	(6) Oil	
	(7) Handling the SSR	
3-4	PCB-mounting SSR	35
	(1) Suitable PCB	
	(2) Mounting Space and Direction	
	(3) Mounting SSR to PCB	

4 SSR Reliability	37
4-1 Failure Rate and Life Expectancy.....	37
4-2 Quality and Reliability.....	37
4-3 Reliability Test.....	37
4-4 Noise Test.....	37
4-5 Dielectric Strength and Insulation Resistance.....	37
4-6 Dielectric Strength of Internal Elements.....	37
5 Q&A	38
Q1. What is the zero cross function?.....	38
Q2. Why does the input current vary with the SSR?.....	38
Q3. What is the difference in switching with a thyristor and a triac?.....	39
Q4. What are the characteristics of thyristors and triacs?.....	39
Q5. What is a snubber circuit?.....	39
Q6. What is a hybrid SSR?.....	40
Q7. Are there any SSRs with normally closed contacts?.....	40
Q8. What is the soft start function?.....	40
Q9. What do the model numbers mean?.....	41
Q10. What is the difference between recommended values and rated values?.....	41
Q11. What is the counter-electromotive force?.....	41
Q12. What is the meaning of I^2t for fuse selection?.....	42
Q13. Why does the operating time vary between AC inputs and DC inputs?.....	42
Q14. What is the relationship between the leakage current and load voltage?.....	42
Q15. Is it possible to connect SSRs in series?.....	43
Q16. Is it possible to connect two 200-VAC SSRs in series to a 400-VAC load?.....	43
Q17. Is it possible to connect SSRs in parallel?.....	43
Q18. Is it possible to connect a DC output load to a negative electrode? Can either a positive or negative load be connected?.....	43
Q19. What portion of the power factor of the load is practically applicable?.....	43
Q20. Why is the minimum load current for most SSRs limited to 0.1 A?.....	44
Q21. Why can most SSRs not switch micro-loads?.....	44
Q22. Why does a relay make noise when switched with an SSR?.....	44
Q23. Why is the current not stable when the power supply is switched ON and OFF?.....	45
Q24. What are the ideal pattern widths and pitches on a PCB?.....	45
Q25. How much thermal resistance is required in the heat sink? What is the thermal resistance of the SSR?.....	46
Q26. Can a panel frame be used in place of a heat sink?.....	46
Q27. What are the carry current characteristics of the radiator?.....	46
Q28. What is silicon grease?.....	47
Q29. What output configuration is suitable when the SSR is used in combination with a temperature controller?.....	47

Q30. What precautions are necessary when driving a number of SSRs with temperature outputs? 47

Q31. Is it possible to protect the motor with an SSR and mechanical thermal? 49

Q32. What precautions are necessary for forward/reverse operation of the single-phase motor? 49

Q33. Is it possible to use a three-phase SSR to turn three single-phase circuits ON and OFF? 50

Q34. Why is a time lag required between the forward operation and reverse operation of a three-phase motor? 50

Q35. Does an SSR have a mounting direction? 50

Q36. What precautions are required for high-density mounting or gang mounting? 51

Q37. What is the non-repetitive inrush current? 52

Q38. What kind of failure do SSRs have most frequently? 53

Q39. What will happen if the load voltage exceeds the upper limit? 53

Q40. Is it possible to replace a defective part in an SSR? 53

Q41. How can we use a multimeter to check if the SSR is ON or OFF? 53

Q42. Are there any methods to check whether an old SSR works or not? 53

Q43. Why can MOS FET relays be used for both AC and DC loads? 53

Q44. What are the differences between SSRs and power MOS FET relays? 54

Q45. What kind of applications can power MOS FET relays be used for? 54

6 SSR Troubleshooting Flowcharts 55

Index 57

1 Basic Concepts of SSRs

1-1 What Are SSRs?

(1) Difference between SSRs and Mechanical Relays

SSRs (Solid State Relays) have no movable contacts. SSRs are not very different in operation from mechanical relays that have movable contacts. SSRs, however, employ semiconductor switching elements, such as thyristors, triacs, diodes, and transistors. Furthermore, SSRs employ optical semiconductors called photocouplers to isolate input and output signals. Photocouplers change electric signals into optical signals and relay the signals through space, thus fully isolating the input and output sections while relaying the signals at high speed.

SSRs consist of electronic parts with no mechanical contacts. Therefore, SSRs have a variety of features that mechanical relays do not incorporate. The greatest feature of SSRs is that SSRs do not use switching contacts that will physically wear out.

SSRs are ideal for a wide range of applications due to the following performance characteristics.

- They provide high-speed, high-frequency switching operations.
- They have no contact failures.
- They generate little noise.
- They have no arc noise.

Configuration of SSRs

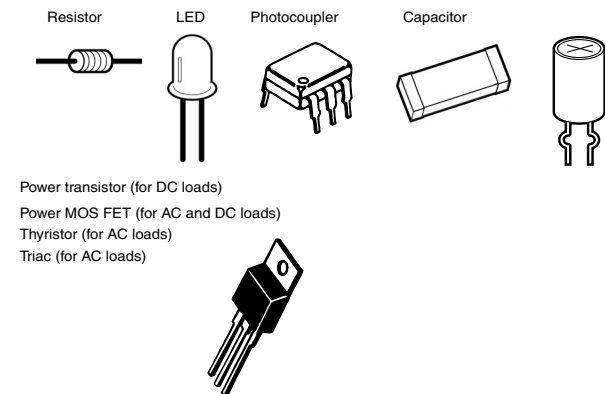
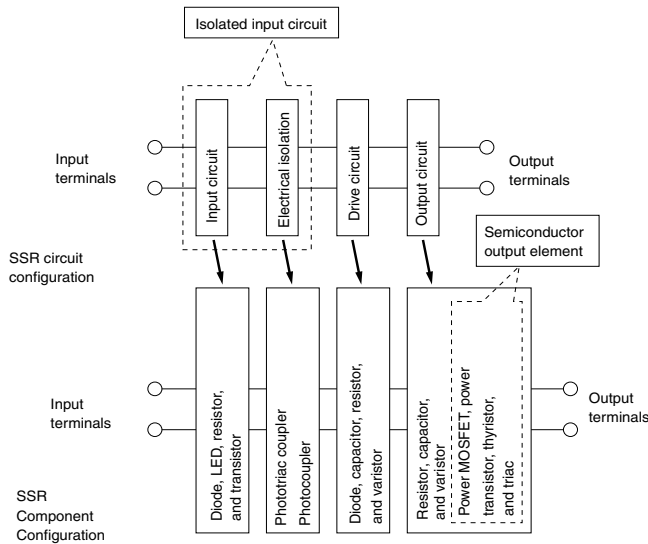

SSRs (Representative Example of Switching for AC Loads)

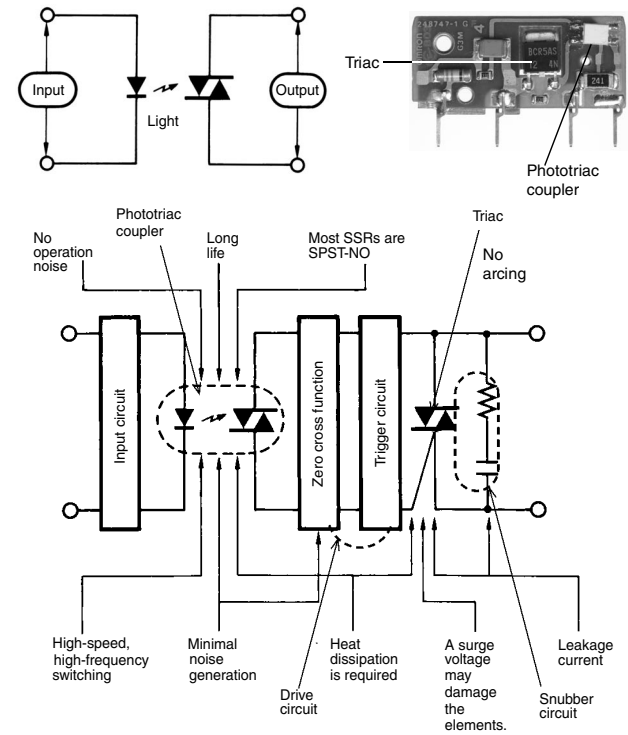

Electromagnetic Relay (EMR)

An EMR generates electromagnetic force when input voltage is applied to the coil. The electromagnetic force moves the armature that switches the contacts in synchronization. EMRs are not only mounted to control panels, but also used for a wide range of applications. The principle of the operation of EMRs is simple and it is possible to manufacture EMRs at low costs.

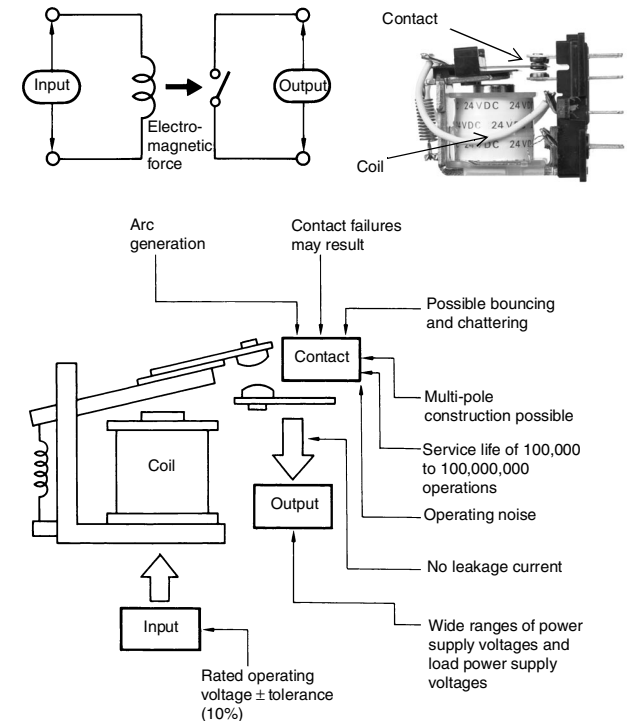

(2) Control of SSRs (ON/OFF Control, Cycle Control, Phase Control)

ON/OFF control is a form of control where a heater is turned ON or OFF by turning an SSR ON or OFF in response to voltage output signals from a Temperature Controller. The same kind of control is also possible with an electromagnetic relay but if control where the heater is turned ON and OFF at intervals of a few seconds over a period of several years, then an SSR must be used. With cycle control (G32A-EA), output voltage is turned ON/OFF at a fixed interval of 0.2 s. Control is performed in response to current output from a Temperature Controller in the range 4 to 20 mA.

Note Precaution for Cycle Control

With cycle control, current flows five times every second (because the control cycle is 0.2 s). With a transformer load, the following problems may occur due to the large input current (approximately 10 times the rated current), and controlling the power at the transformer primary side may not be possible.

1. The SSR may be destroyed if there is not sufficient leeway in the SSR rating.
2. The breaker on the load circuit may be tripped.

With phase control, output is changed every half-cycle in response to current output signals in the range 4 to 20 mA from a Temperature Controller. Using this form of control, high-precision temperature control is possible, and is used widely with semiconductor equipment.

ON/OFF Control

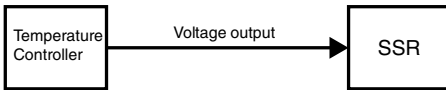
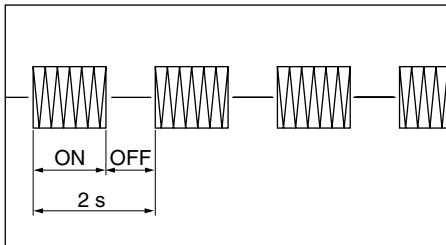

Enables low-cost, noiseless operation without maintenance requirements.

Cycle Control

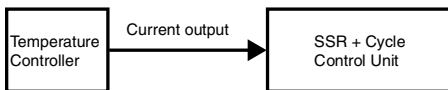
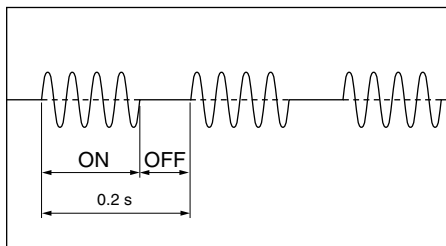

Enables noiseless operation with high-speed response.

Phase Control (Single Phase)

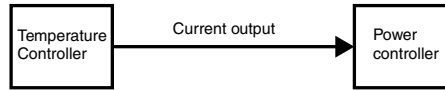
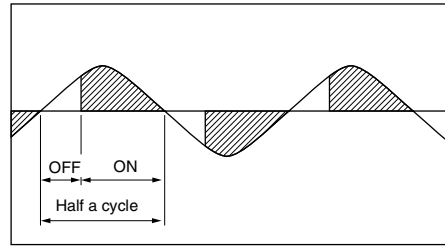

Enables precise temperature control and increases the heater's service life.

(3) Configuration and Operating Principle of MOS FET Relays

MOS FET relays are SSRs that use power MOS FETs in output elements. In order to operate the power MOS FETs, photodiode arrays are used as light-receiving elements. When current flows into the input terminal, the LED lights. This light generates a photoelectromotive force in the photodiode array, and this acts as a gate voltage that turns ON the power MOS FET. By connecting 2 power MOS FETs using a source common, control of AC loads is possible. There are models for control of DC loads, which have just one power MOS FET. (Refer to Q43, Q44, and Q45 in Q&A.)

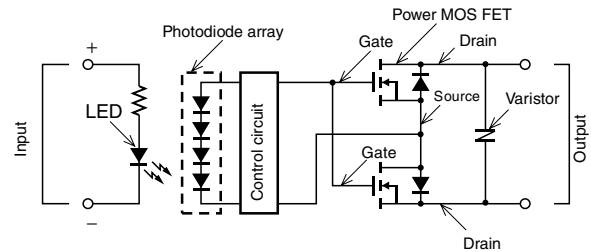

There is no varistor in the G3VM MOS FET relay for signalling.

(4) SSR Application Examples

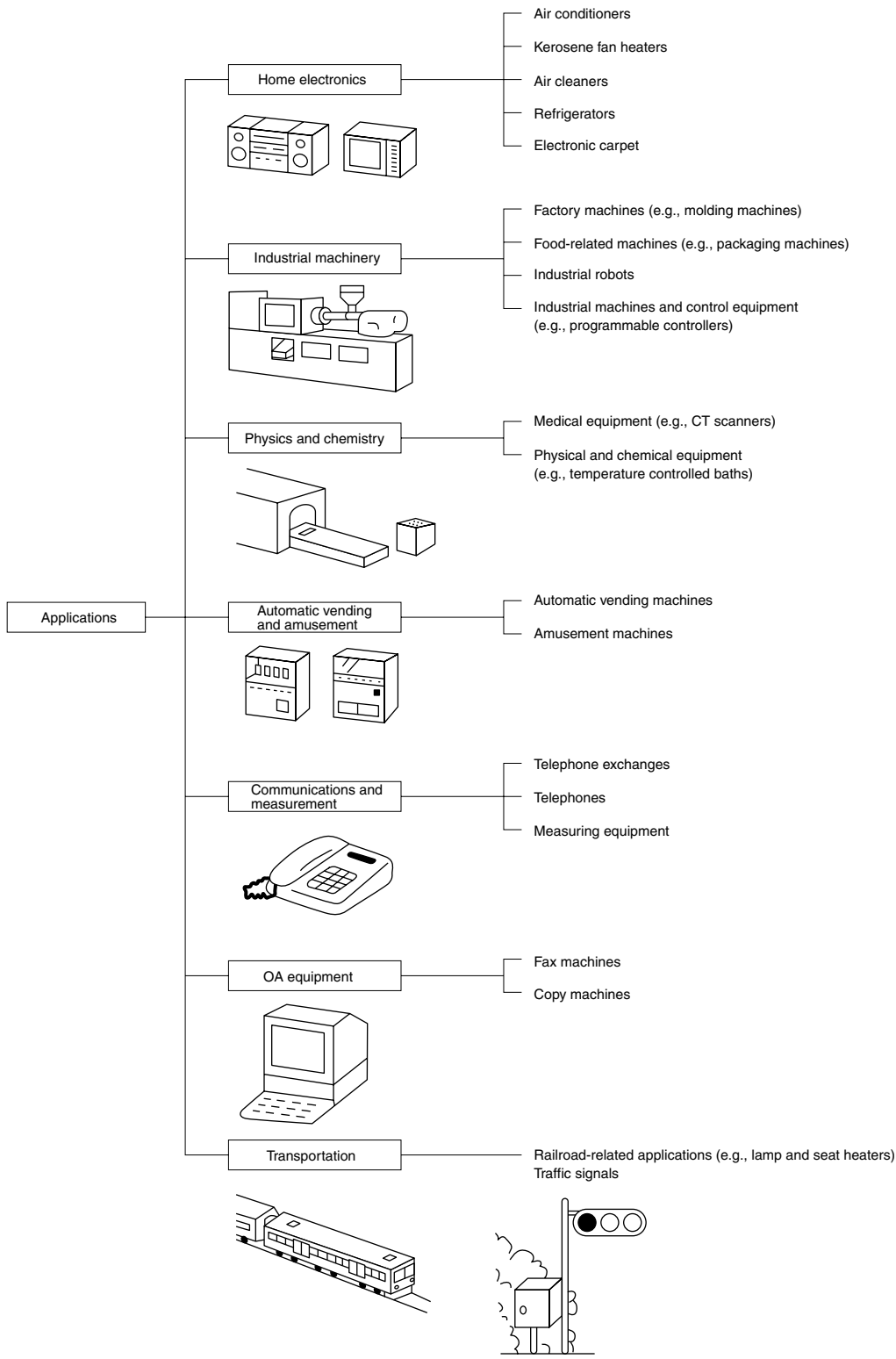

SSRs are used for a variety of electric machines and devices



(5) SSR Classifications

SSRs can be classified by appearance, such as panel-mounting models, socket models, or PCB models, or by applications, as shown below. The optimum SSR can be selected depending on the purpose, and this is another important feature of SSRs.

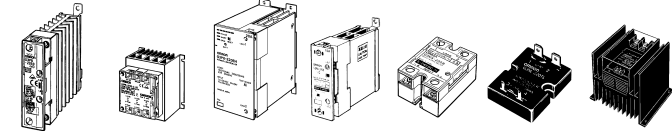
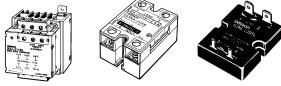
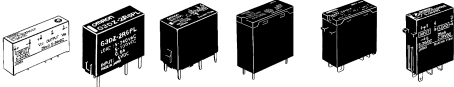
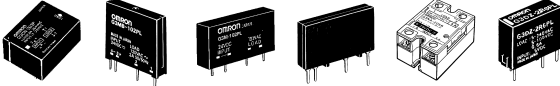
Classification by Application

Application	Recommended SSRs
<p>Heater Control These SSRs are applicable to machines which require highly sensitive temperature control for turning heaters ON and OFF, such as molding equipment, packaging machines, and solderers. These SSRs feature plug-in models, replaceable power element cartridge models, and built-in heat sink model. They meet the high-capacity, high ON/OFF frequency requirements of heater control.</p>	 <p>Single-phase G3PB Three-phase G3PB G3PX G3PA G3NA G3NE G3NH</p>
<p>Motor Control These SSRs are applicable to machines which require motor inching operation and reversible operation, such as machine tools, conveyors, and packaging equipment. They have high-speed response time and high ON/OFF frequency, required for inching and reversible operation.</p>	 <p>G3J G3NA G3NE</p>
<p>I/O These SSRs meet the requirements for isolated transmission of control output from PCs and Position Controllers to an actuator. In particular, the G3DZ and G3RZ Relays use MOS FET in the output element to allow shared use of the Relays in both low-leakage-current AC and DC circuits.</p>	 <p>G3TB G3DZ G3S (D) G3R (I/O) G3RZ G3TA</p>
<p>Office Automation, Home Automation, Amusement Machines These SSRs have high ON/OFF frequency, noiseless operation, and when compared to mechanical relays, have greater resistance to vibration, shock, dust and dirt, and gas, making them ideal for situations where these factors are important.</p>	 <p>G3CN G3MB G3M G3MC G3NA G3DZ</p>
<p>Panel-mounted Interfaces These SSRs are the same shape as general-purpose relays, they have the same sockets and can be mounted according to their respective shapes. They are ideal for interface applications where high-frequency switching is required, and can also be used in a wide variety of general-purpose applications, such as directly switching loads.</p>	 <p>G3B G3F G3H G3R</p>

(6) SSR Glossary

	Terms	Meaning
Insulation	Basic insulation	Insulation for basic protection from electric shock (IEC950 1.2.9.2)
	Supplemental insulation	Independent insulation provided outside of basic insulation to protect from electric shock when the basic insulation breaks down (IEC950 1.2.9.3)
	Reinforced insulation	A single-layer of insulation (IEC950 1.2.9.5) that provides the same protection from electric shock as double insulation (insulation including both basic and supplemental insulation) according to conditions stipulated in IEC950 standards
Circuit functions	Zero cross circuit	A circuit which starts operation with the AC load voltage at close to zero-phase.
	Trigger circuit	A circuit for controlling the triac or thyristor trigger signal, which turns the load current ON and OFF.
Input	Isolated input circuit	If the external circuit is prone to generating noise, or if wires from external sources are prone to the influence of inductive noise, in order to prevent malfunctions due to noise, it is necessary to electrically isolate internal circuits and external circuits (output circuits). An isolated input circuit is a circuit that isolates inputs and outputs by using components that are not connected electrically but that can transmit signals, such as contact relays or photocouplers.
	Photocoupler	A component that runs the electric signal into a light emitter (e.g., LED), changes it to a light signal, and then returns it to an electric signal using a photoelectric conversion element, such as a photo transistor. The space used for transferring the light signal is isolated thus providing good insulation and a high propagation speed.
	Rated voltage	The voltage that serves as the standard value of an input signal voltage
	Must-operate voltage	Minimum input voltage when the output status changes from OFF to ON.
	Input impedance	The impedance of the input circuit and the resistance of current-limiting resistors used. Impedance varies with the input signal voltage in case of the constant current input method.
	Operating voltage	The permissible voltage range within which the voltage of an input signal voltage may fluctuate.
	Reset voltage	Maximum input voltage when the output status changes from ON to OFF.
	Input current	The current value when the rated voltage is applied.
Output	Load voltage	This is the effective value for the power supply voltage that can be used for load switching or in the continuous-OFF state.
	Maximum load current	The effective value of the maximum current that can continuously flow into the output terminals under specified cooling conditions (i.e., the size, materials, thickness of the heat sink, and an ambient temperature radiating condition).
	Leakage current	The effective value of the current that can flow into the output terminals when a specified load voltage is applied to the SSR with the output turned OFF.
	Output ON voltage drop	The effective value of the AC voltage that appears across the output terminals when the maximum load current flows through the SSR under specified cooling conditions (such as the size, material, and thickness of heat sink, ambient temperature radiation conditions, etc.).
	Minimum load current	The minimum load current at which the SSR can operate normally.
	Snubber circuit	A circuit consisting of a resistor R and capacitor C, which prevents faulty ignition from occurring in the SSR triac by suppressing a sudden rise in the voltage applied to the triac.
	Semiconductor output element (switching element)	This is a generic name for semiconductors such as the thyristor, triac, power transistor, and power MOS FET. In particular, triacs are often used in SSRs because they allow switching to be performed with one element.
	Repetitive peak OFF-state voltage (VDRM)	This is a rating for an output semiconductor that used in an SSR for AC loads.
	Collector-emitter voltage (VCEO)	This is a rating for an output semiconductor that used in an SSR for DC loads.
Characteristics	Operating time	A time lag between the moment a specified signal voltage is imposed to the input terminals and the output is turned ON.
	Release time	A time lag between the moment the imposed signal input is turned OFF and the output is turned OFF.
	Insulation resistance	The resistance between the input and output terminals or I/O terminals and metal housing (heat sink) when DC voltage is imposed.
	Dielectric strength	The effective AC voltage that the SSR can withstand when it is applied between the input terminals and output terminals or I/O terminals and metal housing (heat sink) for more than 1 minute.
	Ambient temperature and humidity (operating)	The ranges of temperature and humidity in which the SSR can operate normally under specified cooling, input/output voltage, and current conditions.
	Storage temperature	The temperature range in which the SSR can be stored without voltage imposition.

	Terms	Meaning
Others	Inrush current resistance	A current which can be applied for short periods of time to the electrical element.
	Counter-electromotive force	Extremely steep voltage rise which occurs when the load switched or turned OFF.
	Recommended applicable load	The recommended load capacity which takes into account the safety factors of ambient temperature and inrush current.
	Bleeder resistance	The resistance connected in parallel to the load in order to increase apparently small load currents, so that the ON/OFF of minute currents functions normally. (It is also used to shunt leakage currents.)

2 Designing SSR Circuits

2-1 Input Circuit

(1) Input Noise

SSRs need only a small amount of power to operate. This is why the input terminals must shut out electrical noise as much as possible. Noise applied to the input terminals may result in malfunction. The following describe measures to be taken against pulse noise and inductive noise.

1. Pulse Noise

A combination of capacitor and resistor can absorb pulse noise effectively. The following is an example of a noise absorption circuit with capacitor C and resistor R connected to an SSR.

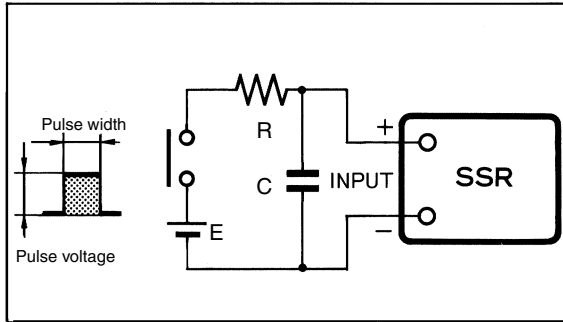

The value of R and C must be decided carefully. The value of R must not be too large or the supply voltage (E) will not be able to satisfy the required input voltage value. The larger the value of C is, the longer the release time will be, due to the time required for C to discharge electricity.

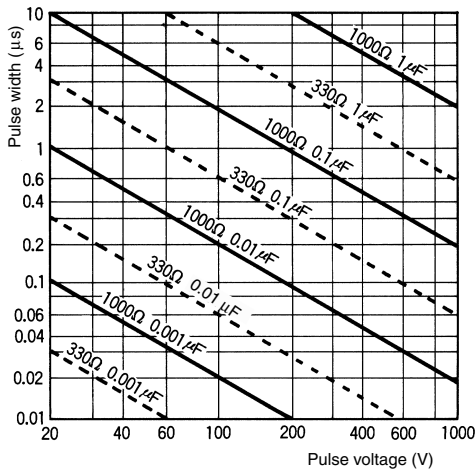

Note For low-voltage models, sufficient voltage may not be applied to the SSR because of the relationship between C, R, and the internal impedance. When deciding on a value for R, check the input impedance for the SSR.

2. Inductive Noise

Do not wire power lines alongside the input lines. Inductive noise may cause the SSR to malfunction. If inductive noise is imposed on the input terminals of the SSR, use the following cables according to the type of inductive noise, and reduce the noise level to less than the reset voltage of the SSR.

Twisted-pair wires: For electromagnetic noise

Shielded cable: For static noise

A filter consisting of a combination of capacitor and resistor will effectively reduce noise generated from high-frequency equipment.

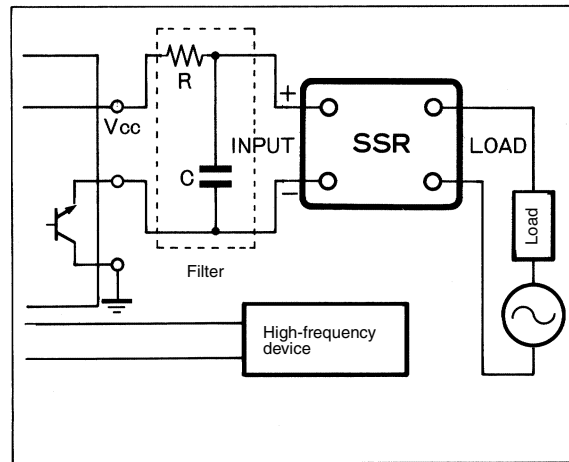

Note R: 20 to 100 Ω
C: 0.01 to 1 μF

(2) Input Conditions

1. Input Voltage Ripples

When there is a ripple in the input voltage, set so that the peak voltage is lower than the maximum operating voltage and the root voltage is above the minimum operating voltage.

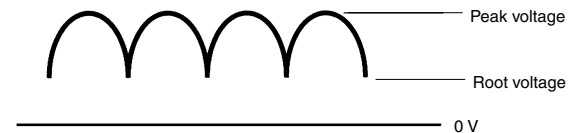

2. Countermeasures for Leakage Current

When the SSR is powered by transistor output, the reset voltage may be insufficient due to leakage current of transistor during power OFF. To counteract this, connect bleeder resistance R as shown in the diagram below and set the resistance so that the voltage applied to both ends of the resistance is less than half of the reset voltage of the SSR.

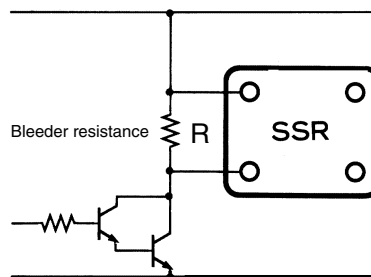

The bleeder resistance R can be obtained in the way shown below.

$$R \leq \frac{E}{I_L - I}$$

E: Voltage applied at both ends of the bleeder resistance = half of the reset voltage of the SSR

I_L: Leakage current of the transistor

I: Reset current of the SSR

The actual value of the reset current is not given in the datasheet and so when calculating the value of the bleeder resistance, use the following formula.

$$\text{Reset current for SSR} = \frac{\text{Minimum value of reset voltage}}{\text{Input impedance}}$$

For SSRs with constant-current input circuits (e.g., G3NA, G3PA, G3PB), calculation is performed at 0.1 mA.

The calculation for the G3M-202P DC24 is shown below as an example.

$$\text{Reset current } I = \frac{1 \text{ V}}{1.6 \text{ k}\Omega} = 0.625 \text{ mA}$$

$$\text{Bleeder resistance } R = \frac{1 \text{ V} \times 1/2}{I_L - 0.625 \text{ mA}}$$

3. ON/OFF Frequency

The ON/OFF frequency should be set to 10 Hz maximum for AC load ON/OFF and 100 Hz maximum for DC load ON/OFF. If ON/OFF occurs at frequencies exceeding these values, SSR output will not be able to follow up.

4. Input Impedance

In SSRs which have wide input voltages (such as G3F and G3H), the input impedance varies according to the input voltage and changes in the input current. If the input voltage is low, the influence of the voltage drop for the input LED is large, and the input impedance will be higher than expected. If the voltage is so high that the LED voltage drop can be ignored, the input impedance will be close to the resistance R.

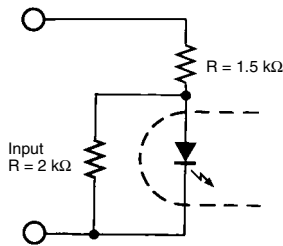

For semiconductor-driven SSRs, changes in voltage can cause malfunction of the semiconductor, so be sure to check the actual device before usage. See the following examples. Refer to the SSR's datasheet for the impedance of individual SSR models.

Applicable Input Impedance for a Photocoupler-type SSR without Indicators (Example) G3F, G3H (Without Indicators)

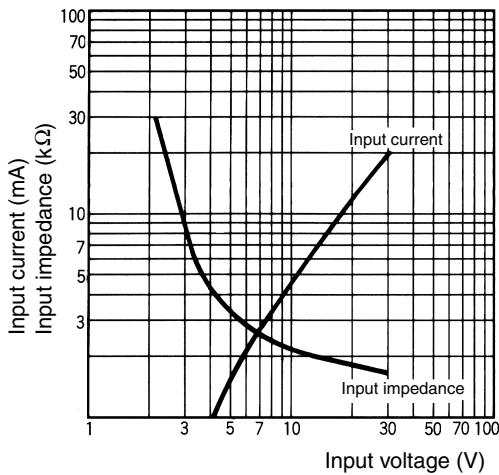

Applicable Input Impedance for a Photocoupler-type SSR with Indicators (Example) G3B, G3F, G3H (With Indicators)

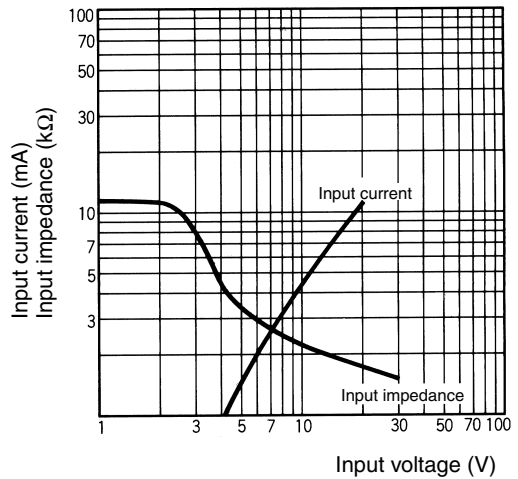

Applicable Input Impedance (Example) G3CN

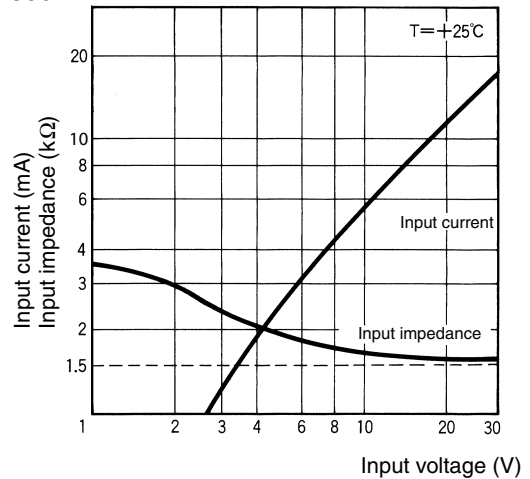

2-2 Output Circuit

(1) AC ON/OFF SSR Output Noise Surges

If there is a large voltage surge in the AC current being used by the SSR, the C/R snubber circuit built into the SSR between the SSR load terminals will not be sufficient to suppress the surge, and the SSR transient peak element voltage will be exceeded, causing overvoltage damage to the SSR.

There are SSR models that do not have a built-in surge absorbing varistor. (Refer to the SSR's datasheet for details.) When switching the inductive load ON and OFF, be sure to take countermeasures against surge, such as adding a surge absorbing element.

In the following example, a surge voltage absorbing element is added. Basically, if the SSR does not have a built-in varistor, A will be effective, and if the SSR does have a built-in varistor, B will be effective. In practice, it is necessary to confirm correct operation under actual operating conditions.

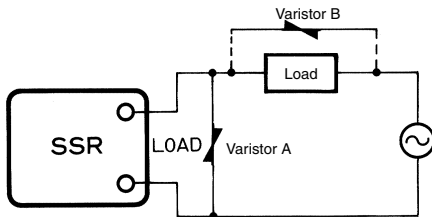

Select an element which meets the conditions in the table below as the surge absorbing element.

Voltage	Varistor voltage	Surge resistance
100 to 120 VAC	240 to 270 V	1,000 A min.
200 to 240 VAC	440 to 470 V	
380 to 480 VAC	820 to 1,000 V	

(2) DC ON/OFF SSR Output Noise Surges

When an L load, such as a solenoid or electromagnetic valve is connected, connect a diode that prevents counter-electromotive force. If the counter-electromotive force exceeds the withstand voltage of the SSR output element, it could result in damage to the SSR output element. To prevent this, insert the element parallel to the load, as shown in the following diagram and table.

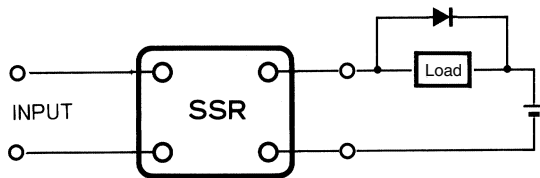

As an absorption element, the diode is the most effective at suppressing the counter-electromotive force. The release time for the solenoid or electromagnetic valve will, however, increase. Be sure to check the circuit before use. To shorten the time, connect a Zener diode and a regular diode in series. The release time will be shortened at the same rate that the Zener voltage (V_z) of the Zener diode is increased.

• Absorption Element Example

Absorption element				
	Diode	Diode + Zener diode	Varistor	CR
Effectiveness	○	○	△	×

(Reference)

1. Selecting a Diode
Withstand voltage = $V_{RM} \geq \text{Power supply voltage} \times 2$
Forward current = $I_F \geq \text{load current}$
2. Selecting a Zener Diode
Zener voltage = $V_z < \text{SSR's connector-emitter voltage} - (\text{Power supply voltage} + 2 \text{ V})$
Zener surge reverse power = $P_{RSM} > V_z \times \text{Load current} \times \text{Safety factor (2 to 3)}$

Note When the Zener voltage is increased (V_z), the Zener diode capacity (P_{RSM}) is also increased.

(3) AND Circuits with DC Output SSRs

Use the G3DZ or G3RZ for the following type of circuit. Do not use standard SSRs, or otherwise the circuit may not be reset.

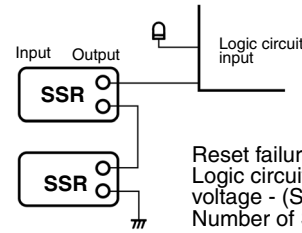

Reset failure will occur in the following case:
Logic circuit input voltage < Power supply voltage - (SSR's output ON voltage drop x Number of SSRs)

(4) Self-holding Circuits

Self-holding circuits must use mechanical relays. SSRs cannot be used to design self-holding circuits.

(5) Selecting an SSR with Differing Loads

The following provides examples of the inrush currents for different loads.

• AC Load and Inrush Current

Load						
	Solenoid	Incan descent lamp	Motor	Relay	Capacitor	Resistance load
Inrush current/Normal current	Approx. 10 times	Approx. 10 to 15 times	Approx. 5 to 10 times	Approx. 2 to 3 times	Approx. 20 to 50 times	1
Waveform						

1. Heater Load (Resistive Load)

Load without an inrush current. Generally used together with a voltage-output temperature controller for heater ON/OFF switching. When used with an SSR with zero cross function, suppresses most noise generated. This type of load does not, however, include all-metal and ceramic heaters. Since the resistance values at normal temperatures of all-metal and ceramic heaters are low, an overcurrent will occur in the SSR, causing damage. For switching of all-metal and ceramic heaters, select a Power Controller (G3PX) with a long soft-start time, or a constant-current type SSR.

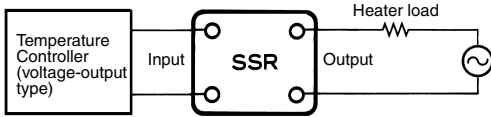

2. Lamp Load

Large inrush current flows through incandescent lamps, halogen lamps, and so on (approx. 10 to 15 times higher than the rated current value). Select an SSR so that the peak value of inrush current does not exceed half the inrush current resistance of the SSR. Refer to "Repetitive" (indicated by dashed lines) shown in the following figure. When a repetitive inrush current of greater than half the inrush current resistance is applied, the output element of the SSR may be damaged. (Refer to Q37 in Q&A.)

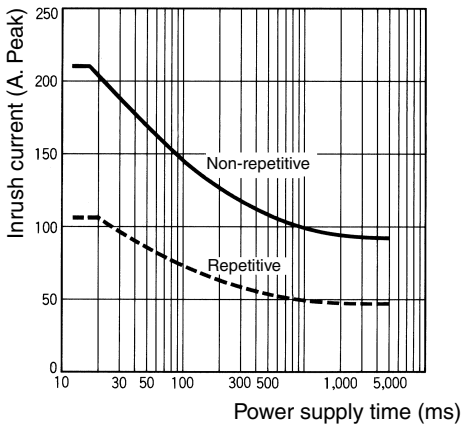

If an SSR is used to switch a fluorescent lamp, the waveform of the power supply voltage will be distorted, and flickering will occur. Fluorescent lamps are discharge tubes, and have transformers for producing high voltages. For this reason, noise and harmonics are generated as a result of distortions in the power supply voltage, small phase gaps, and differences in positive and negative ON-voltages.

3. Motor Load

When a motor is started, an inrush current of 5 to 10 times the rated current flows and the inrush current flows for a longer time. In addition to measuring the startup time of the motor or the inrush current during use, ensure that the peak value of the inrush current is less than half the inrush current resistance when selecting an SSR. The SSR may be damaged by counter-electromotive force from the motor. So when the SSR is turned OFF, be sure to install overcurrent protection.

4. Transformer Load

When the SSR is switched ON, an energizing current of 10 to 20 times the rated current flows through the SSR for 10 to 500 ms. If there is no load in the secondary circuit, the energizing current will reach the maximum value. Select an SSR so that the energizing current does not exceed half the inrush current resistance of the SSR. (Refer to page 18.)

5. Half-wave Rectified Circuit

AC electromagnetic counters and solenoids have built-in diodes, which act as half-wave rectifiers. For these types of loads, a half-wave AC voltage does not reach the SSR output. For SSRs with the zero cross function, this can cause them not to turn ON. Two methods for counteracting this problem are described below.

(a) Connect a bleeder resistance with approximately 20% of the SSR load current.

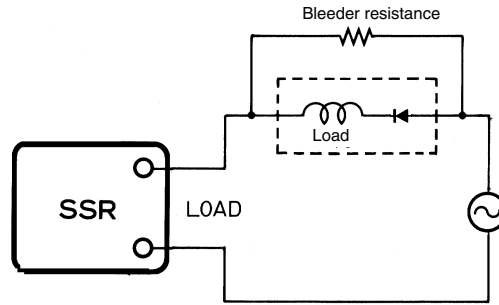

(b) Use SSRs without the zero cross function.

6. Full-wave Rectified Loads

AC electromagnetic counters and solenoids have built-in diodes which act as full-wave rectifiers. The load current for these types of loads has a rectangular wave pattern, as shown in the diagram below.

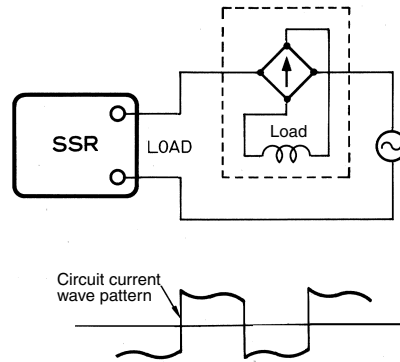

Accordingly, AC SSRs use a triac (which turns OFF the element only when the circuit current is 0 A) in the output element. If the load current waveform is rectangular, it will result in a SSR reset error. When switching ON and OFF a load whose waves are all rectified, use a -V model or Power MOS FET Relay.

-V-model SSRs: G3F-203SL-V, G3H-203SL-V
Power MOS FET Relay: G3DZ, G3RZ, G3FM

7. Small-capacity Loads

Even when there is no input signal to the SSR there is a small leakage current (I_L) from the SSR output (LOAD). If this leakage current is larger than the load release current the SSR may fail to reset.

Connect the bleeder resistance R in parallel to increase the SSR switching current.

$$R < \frac{E}{I_L - I} \quad \begin{array}{l} E: \text{Load (relays etc.) reset voltage} \\ I: \text{Load (relays etc.) reset current} \end{array}$$

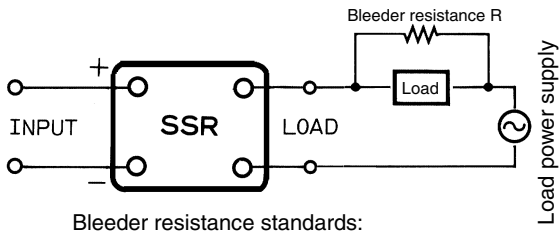

Bleeder resistance standards:
 100-VAC power supply, 5 to 10 kΩ, 3 W
 200-VAC power supply, 5 to 10 kΩ, 15 W

A voltage equal to this SSR's leakage current I_L (mA) × Impedance of the load is applied to both ends of the resistance. A bleeder resistance is used to make this voltage less than the load's reset voltage.

8. Inverter Load

Do not use an inverter-controlled power supply as the load power supply for the SSR. Waveforms for inverter-controlled voltages are rectangular. Semiconductor output elements (triac, thyristor) may not be able to respond to the steep voltage increases (dV/dt becomes extremely large), and the SSR may fail to reset (also called turn-OFF problem or commutating dV/dt failure). An inverter-controlled power supply may be used on the input side provided the effective voltage is within the normal operating voltage range of the SSR.

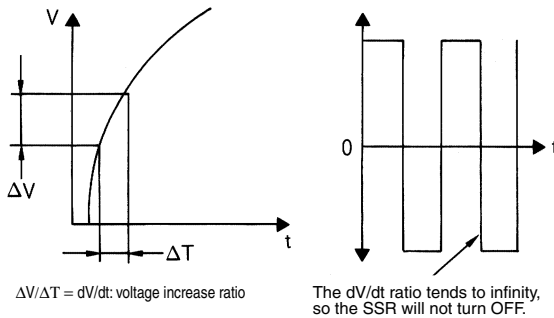

9. Capacitive Load

The supply voltage plus the charge voltage of the capacitor is applied to both ends of the SSR when it is OFF. Therefore, use an SSR model with an input voltage rating twice the size of the supply voltage.

Limit the charge current of the capacitor to less than half the peak inrush current value allowed for the SSR.

(6) Inrush Currents to Transformer Loads

The inrush current from a transformer load will reach its peak when the secondary side of the transformer is open, when no mutual reactance will work. It will take half a cycle of the power supply frequency for the inrush current to reach its peak, the measurement of which without an oscilloscope will be difficult.

The inrush current can be, however, estimated by measuring the DC resistance of the transformer.

Due to the self-reactance of the transformer in actual operation, the actual inrush current will be less than the calculated value.

$$I_{\text{peak}} = V_{\text{peak}}/R = (\sqrt{2} \times V)/R$$

If the transformer has a DC resistance of 3 Ω and the load power supply voltage is 220 V, the following inrush current will flow.

$$I_{\text{peak}} = (1.414 \times 220)/3 = 103.7 \text{ A}$$

The inrush current resistance of OMRON's SSRs is specified on condition that the SSRs are in non-repetitive operation. If your application requires repetitive SSR switching, use an SSR with an inrush current resistance twice as high as the rated value (I_{peak}).

In the case above, use the G3□□-220□ with an inrush current resistance of 207.4 A or more.

The DC resistance of the transformer can be calculated back from the inrush current resistance by using the following formula.

$$R = V_{\text{peak}}/I_{\text{peak}} = (\sqrt{2} \times V)/I_{\text{peak}}$$

For applicable SSRs based on the DC resistance, refer to the tables on page 19.

These tables list SSRs with corresponding inrush current conditions. When using SSRs to actual applications, however, check that the steady-state currents of the transformers satisfy the rated current requirement of each SSR.

SSR Rated Current

G3□□-240□

The underlined two digits refer to the rated current (i.e., 40 A in the case of the above model).

Three digits may be used for the G3NH only.

G3NH: G3NH-□075B = 75 A
 G3NH-□150B = 150 A

Condition 1: The ambient temperature of the SSR (the temperature inside the panel) is within the rated value specified.

Condition 2: The right heat sink is provided to the SSR.

- Load Power Supply Voltage: 100 to 120 V

Load power supply voltage			Inrush current (A)	SSR inrush current resistance (A)	Applicable SSR				
100 V AC	110 V AC	120 V AC			G3PA	G3PB	G3NA	G3NE	G3NH
Transformer DC resistance (Ω)									
4.8 min.	5.2 min.	5.7 min.	30	60	---	---	-205□	-205□	---
1.9 to 4.7	2.1 to 5.1	2.3 to 5.6	75	150	-210□	-215□	-210□	-210□	---
1.3 to 1.8	1.5 to 2.0	1.6 to 2.2	110	220	-220□	-225□	-220□	-220□	---
0.65 to 1.2	0.71 to 1.4	0.78 to 1.5	220	440	-240□ -260□	-235□ -245□	-240□	---	---
0.36 to 0.64	0.39 to 0.70	0.43 to 0.77	400	800	---	---	---	---	-2075□
0.16 to 0.35	0.18 to 0.38	0.19 to 0.42	900	1,800	---	---	---	---	-2150□

- Load Power Supply Voltage: 200 to 240 V

Load power supply voltage			Inrush current (A)	SSR inrush current resistance (A)	Applicable SSR				
200 V AC	220 V AC	240 V AC			G3PA	G3PB	G3NA	G3NE	G3NH
Transformer DC resistance (Ω)									
9.5 min.	10.4 min.	11.4 min.	30	60	---	---	-205□	-205□	---
3.8 to 9.4	4.2 to 10.3	4.6 to 11.3	75	150	-210□	-215□	-210□	-210□	---
2.6 to 3.7	2.9 to 4.1	3.1 to 4.5	110	220	-220□	-225□	-220□	-220□	---
1.3 to 2.5	1.5 to 2.8	1.6 to 3.0	220	440	-240□ -260□	-235□ -245□	-240□	---	---
0.71 to 1.2	0.78 to 1.4	0.85 to 1.5	400	800	---	---	---	---	-2075□
0.32 to 0.70	0.35 to 0.77	0.38 to 0.84	900	1,800	---	---	---	---	-2150□

- Load Power Supply Voltage: 400 V

Transformer DC resistance (Ω)	Inrush current (A)	SSR inrush current resistance (A)	Applicable SSR			
			G3PA	G3PB	G3NA	G3NH
7.6 min.	75	150	---	---	-410B	---
5.2 to 7.5	110	220	-420B-VD(-2)	-415B-3(-2) -425B-3(-2)	-420B	---
2.6 to 5.1	220	440	-430B-VD(-2) -450B-VD(-2)	-435B-3(-2) -445B-3(-2)	-440B	---
1.5 to 2.5	400	800	---	---	---	-4075B
0.63 to 1.4	900	1,800	---	---	---	-4150B

- Load Power Supply Voltage: 440 V

Transformer DC resistance (Ω)	Inrush current (A)	SSR inrush current resistance (A)	Applicable SSR		
			G3PA	G3NA	G3NH
8.3 min.	75	150	---	-410B	---
5.7 to 8.2	110	220	-420B-VD-2	-420B	---
2.9 to 5.6	220	440	-430B-VD-2 -450B-VD-2	-440B	---
1.6 to 2.8	400	800	---	---	-4075B
0.70 to 1.5	900	1,800	---	---	-4150B

- Load Power Supply Voltage: 480 V

Transformer DC resistance (Ω)	Inrush current (A)	SSR inrush current resistance (A)	Applicable SSR	
			G3PA	G3NA
9.4 min.	75	150	---	-410B
6.2 to 9.0	110	220	-420B-VD-2	-420B
3.1 to 6.1	220	440	-430B-VD-2 -450B-VD-2	-440B

(7) Transformer Tap Selection

SSRs can be used to switch between transformer taps. In this case, however, be aware of voltage induced on the OFF-side SSR. The induced voltage increases in proportion to the number of turns of the winding that is almost equivalent to the tap voltage.

See the following example. The power supply voltage is at 200 V, N1 is 100, N2 is 100, and SSR2 is ON. Then the difference in voltage between output terminals of SSR1 is at 400 V (i.e., twice as high as the power supply voltage).

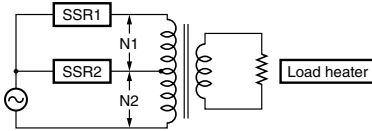

(8) Controlling Power for Transformer Loads

With cycle control, current flows five times every second (because the control cycle is 0.2 s). With a transformer load, the following problems may occur due to the large inrush current (approximately 10 times the rated current), and controlling the power at the transformer primary side may not be possible.

1. The SSR may be destroyed if there is not sufficient leeway in the SSR rating.
2. The breaker on the load circuit may be tripped.

2-3 Load Power Supply

(1) Rectified Currents

If a DC load power supply is used for full-wave or half-wave rectified AC currents, be sure that the peak load current does not exceed the maximum usage load power supply of the SSR. Otherwise, overvoltage will cause damage to the output element of the SSR.

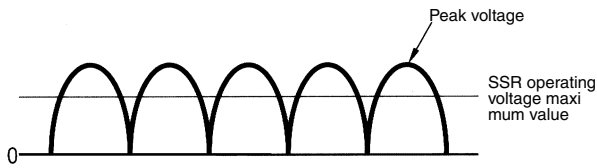

(2) Operating Frequency for AC Load Power Supply

The operating frequency range for AC load power supply is 47 to 63 Hz. This is due to the response speed of the internal triac or thyristor elements of the SSR. Although the SSR operates at less than 47 or 63 to 100 Hz, the performance of the SSR cannot be guaranteed in these ranges. If the frequency exceeds 100 Hz, the SSR cannot switch the load.

If an SSR for AC loads with a triac or thyristor output element operates at a frequency of 0 Hz (i.e., like a DC load), reset failure occurs. This kind of SSR cannot be used for this operation.

(3) Low AC Voltage Loads

If the load power supply is used under voltage below the minimum operating load voltage of the SSR, the loss time of the voltage applied to the load will become longer than that of the SSR operating voltage range. See the following load example. (The loss time is $A < B$.)

Make sure that this loss time will not cause problems, before operating the SSR.

If the load voltage falls below the trigger voltage the SSR will not turn ON, so be sure to set the load voltage to 75 VAC minimum. (24 VAC for G3PA-VD and G3NA-2□□B.)

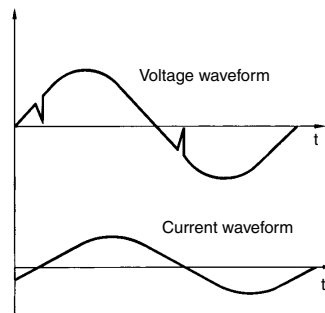
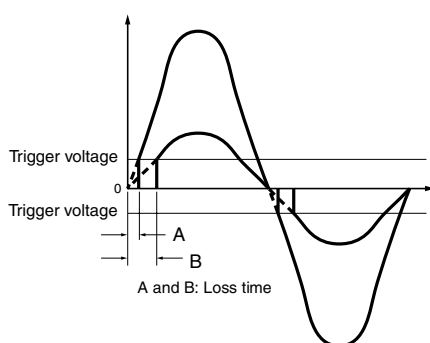

An inductance (L) load causes a current phase delay as shown above. Therefore, the loss is not as great as that caused by a resistive (R) load. This is because a high voltage is already imposed on the SSR when the input current to the SSR drops to zero and the SSR is turned OFF.

(4) Phase-controlled AC Power Supplies

Phase-controlled power supply can be used for POWER MOS FET SSRs but not for SSRs that have triac or thyristor output.

2-4 Application Circuit Examples

(1) Connection to Sensor

The SSR connects directly to the Proximity Sensor and Photoelectric Sensor.

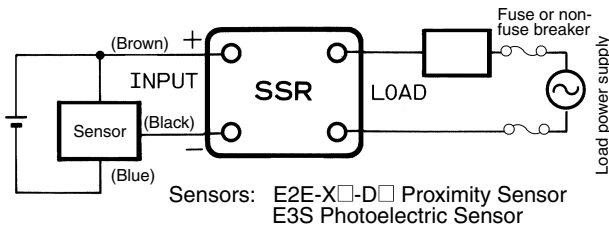

(2) Switching Control of Incandescent Lamp

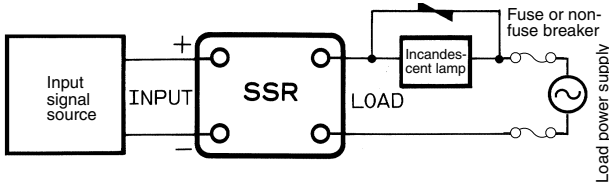

(3) Temperature Control of Electric Furnace

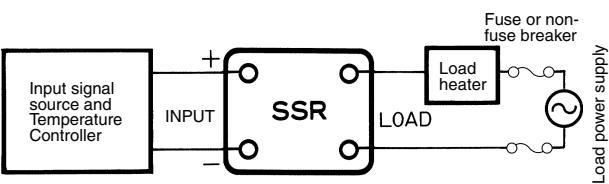

(4) Forward and Reverse Operation of Single-phase Motor

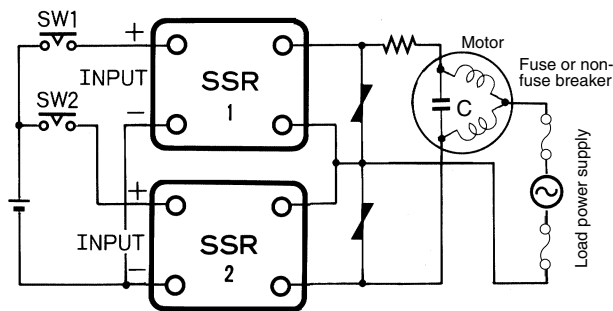

Note: 1. The voltage between the load terminals of either SSR 1 or SSR 2 turned OFF is approximately twice as high as the supply voltage due to LC coupling. Be sure to apply an SSR model with a rated output voltage of at least twice the supply voltage.

For example, if the motor operates at a supply voltage of 100 VAC, the SSR must have an output voltage of 200 VAC or higher.

2. Make sure that there is a time lag of 30 ms or more to switch over SW1 and SW2.

(5) ON/OFF Control of Three-phase Inductive Motor

Single SSRs in Combination

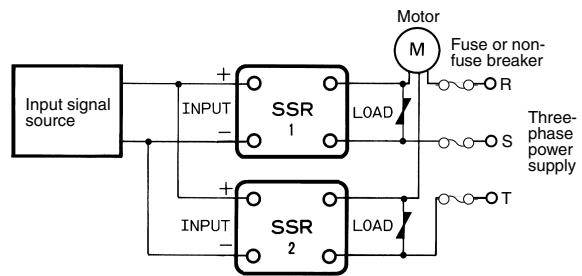

Using G3J-series Solid State Contactor for Three-phase Motor Control

Note Refer to the following pages.

(6) Forward and Reverse Operation of Three-phase Motor

Single SSRs in Combination

Make sure that signals input into the SSR Units are proper if the SSR Units are applied to the forward and reverse operation of a three-phase motor. If SW1 and SW2 as shown in the following circuit diagram are switched over simultaneously, a phase short-circuit will result on the load side, which may damage the output elements of the SSR Units. This is because the SSR has a triac as an output element that is turned ON until the load current becomes zero regardless of the absence of input signals into the SSR.

Therefore, make sure that there is a time lag of 30 ms or more to switch over SW1 and SW2.

The SSR may be damaged due to phase short-circuiting if the SSR malfunctions with noise in the input circuit of the SSR. To protect the SSR from phase short-circuiting damage, the protective resistance R may be inserted into the circuit.

The value of the protective resistance R must be determined according to the withstanding inrush current of the SSR. For example, the G3NA-220B withstands an inrush current of 220 A. The value of the protective resistance R is obtained from the following.

$$R > 220 \text{ V} \times \sqrt{2} / 200\text{A} = 1.4 \Omega$$

Considering the circuit current and weld time, insert the protective resistance into the side that reduces the current consumption.

Obtain the consumption power of the resistance from the following.

$$P = I^2 R \times \text{Safety factor}$$

$$(I = \text{Load current, } R = \text{Protective resistance, Safety factor} = 3 \text{ to } 5)$$

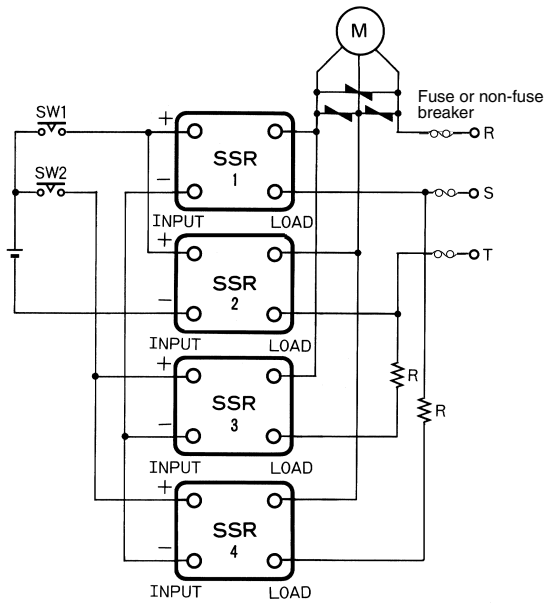

Using G3J-series Solid State Contactor for Three-phase Motor Control

Harmonized protection is ensured for motor overcurrents.

Be sure to supply power to the G3J through a fuse or non-fuse breaker to protect the G3J from damage due to short-circuiting.

Standard Models

**DC-input Models
G3J-□BL, G3J-□BL-2
NPN Transistor Input Circuit**

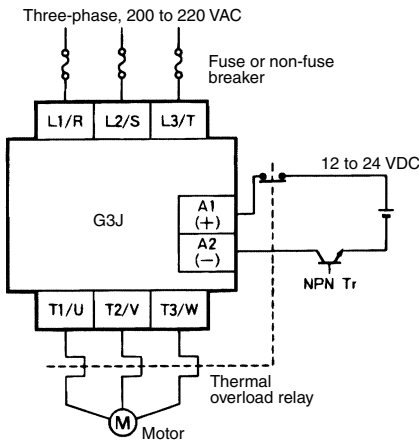

**DC-input Models
G3J-□BL, G3J-□BL-2
PNP Transistor Input Circuit**

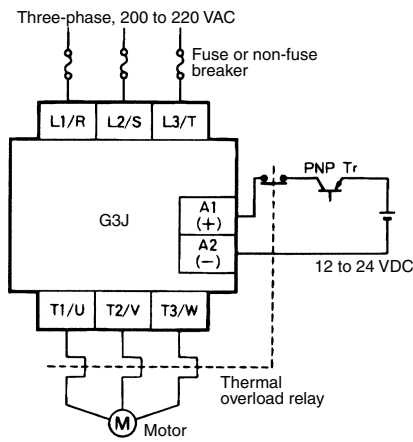

**AC-input Models
G3J-□BL, G3J-□BL-2**

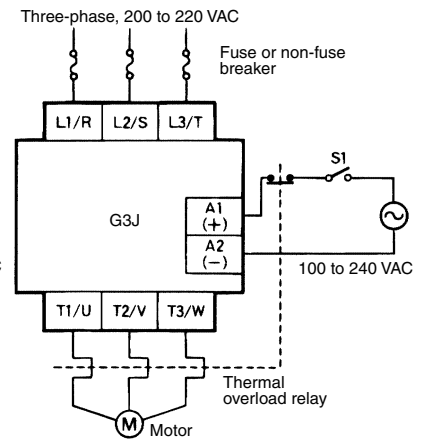

Soft-start/Soft-start/stop Models

G3J-S□BL, G3J-T□BL
NPN Transistor Input Circuit

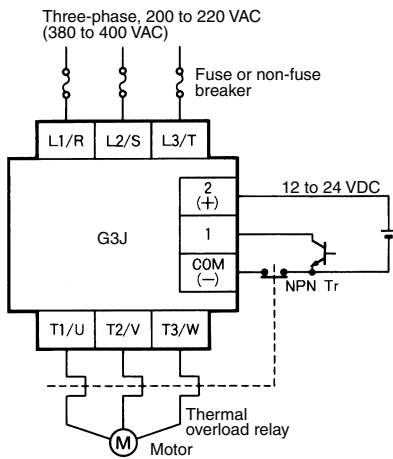

G3J-S□BL, G3J-T□BL
PNP Transistor Input Circuit

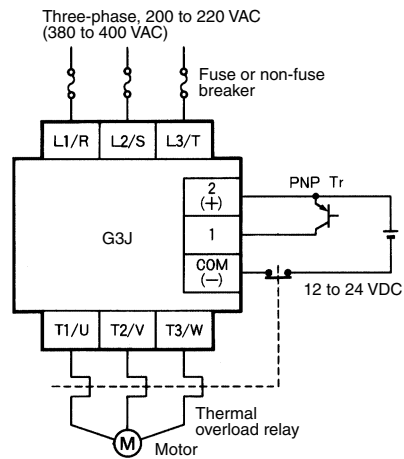

- Note:**
1. When the minimum applicable load of the thermal relay auxiliary contacts becomes smaller than the input current of the G3J, insert a bleeder resistance.
 2. Connect the thermal relay b contact to the 2 (+) or COM (-) line. Connecting the thermal relay b contact to the 1 input will cause contact failure.

Self-hold Circuits

G3J-□BL, G3J-□BL-2

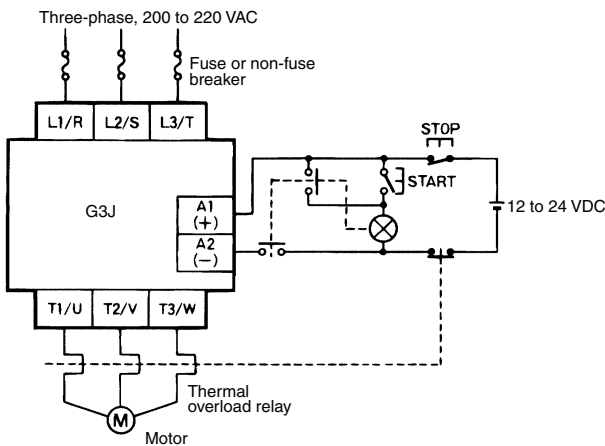

G3J-S□BL, G3J-T□BL

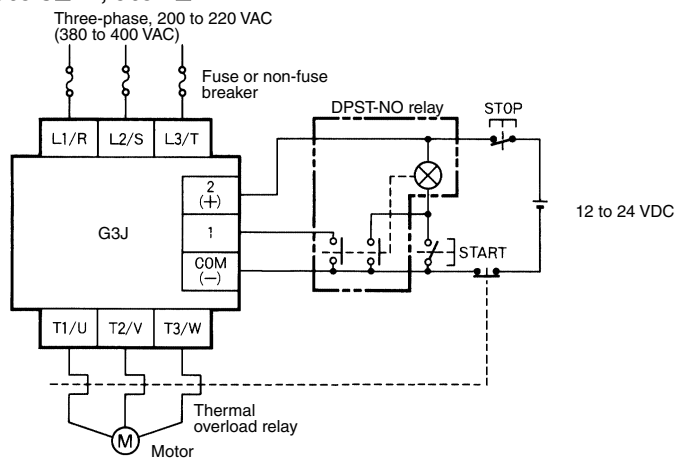

- Note:** Be sure to use a fuse or non-fuse breaker to protect the G3J.

(7) Forward/Reverse Rotation: Example 1

G3J-S or G3J-T with a Reversible Contactor with Built-in Mechanical Interlock Function

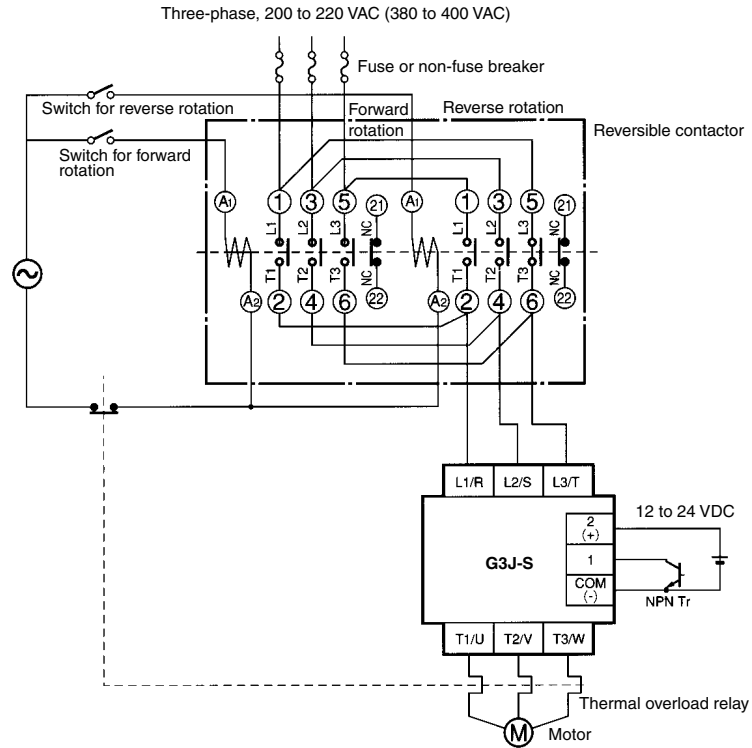

- Note:**
1. Be sure to use a fuse or non-fuse breaker to protect the G3J.
 2. Be sure that the interval between forward and reverse operations is at least 100 ms.
 3. Be sure to apply the input signal of the G3J-S after the reversible contactor starts operating. If the input signal is applied before the contactor starts operating, the soft-start function may not operate.

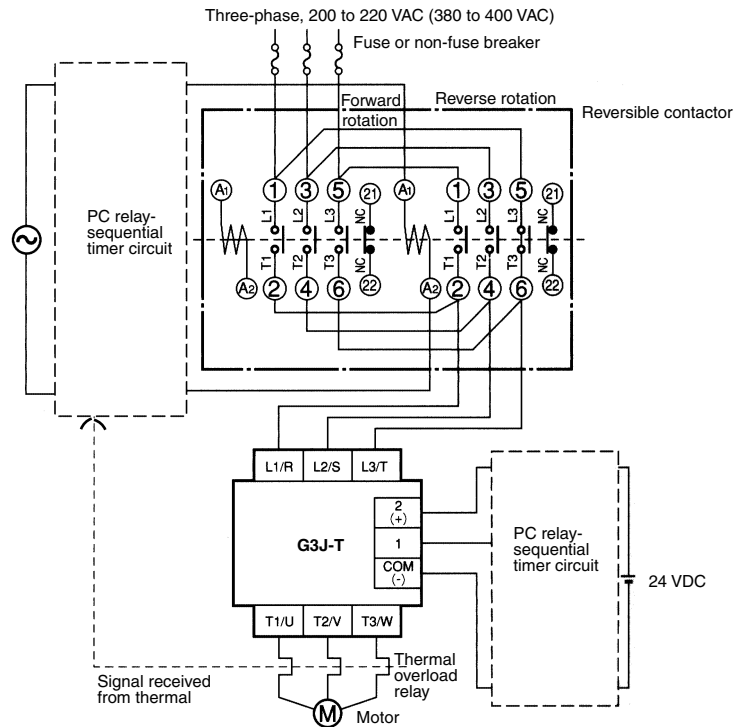

- Note:**
1. Be sure to use a fuse or non-fuse breaker to protect the G3J.

- For soft-stop control, the G3J-T has enough load current to continue rotating the motor during ramp-down time setting even after the control signal of the G3J-T is turned OFF. Therefore, a time lag is required between the time when the G3J-T stops operating up to the time when the reversible contactor is turned OFF. The ramp-down time of the G3J-T is adjustable up to approximately 25 s max. Therefore, set the time lag to 25 s in the initial sequence during the adjustment stage. Adjust the time lag of the sequential circuit according to the application.

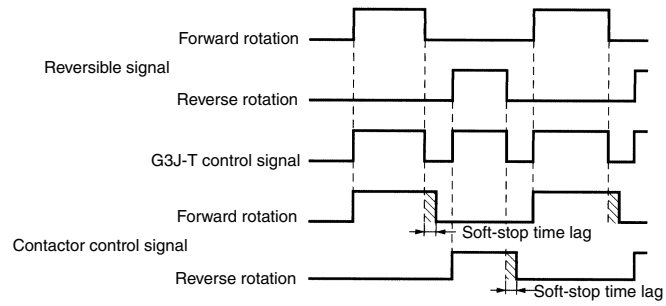

2-5 Fail-safe Concept

(1) Error Mode

The SSR is an optimum relay for high-frequency switching and high-speed switching, but misuse or mishandling of the SSR may damage the elements and cause other problems. The SSR consists of semiconductor elements, and will break down if these elements are damaged by surge voltage or overcurrent. Most faults associated with the elements are short-circuit malfunctions, whereby the load cannot be turned OFF.

Therefore, to provide a fail-safe feature for a control circuit using an SSR, design a circuit in which a contactor or circuit breaker on the load power supply side will turn OFF the load when the SSR causes an error. Do not design a circuit that only turns OFF the load power supply with the SSR. For example, if the SSR causes a half-wave error in a circuit in which an AC motor is connected as a load, DC energizing may cause overcurrent to flow through the motor, thus burning the motor. To prevent this from occurring, design a circuit in which a circuit breaker stops overcurrent to the motor.

Location	Cause	Result
Input area	Overvoltage	Input element damage
Output area	Overvoltage	Output element damage
	Overcurrent	
Whole Unit	Ambient temperature exceeding maximum	Output element damage
	Poor heat radiation	

(2) Short-circuit Protection (Fuse Selection) and Overcurrent Protection

A short-circuit current or an overcurrent flowing through the load of the SSR will damage the output element of the SSR. Connect a quick-break fuse in series with the load as an overcurrent protection measure.

Design a circuit so that the protection coordination conditions for the quick-break fuse satisfy the relationship between the SSR surge resistance (I_s), quick-break fuse current-limiting feature (I_f), and the load inrush current (I_L), shown in the following chart.

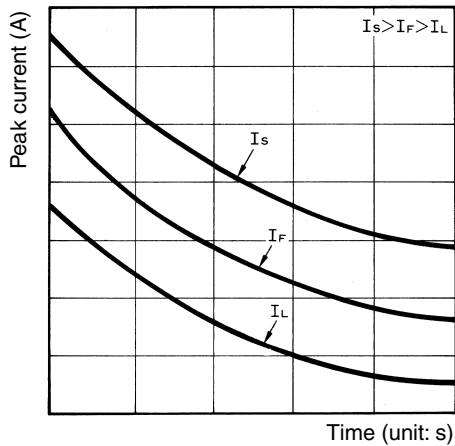

Provide an appropriate non-fuse breaker to each machine for the overcurrent protection of the machine.

(3) Operation Indicator

The operation indicator turns ON when current flows through the input circuit. It does not indicate that the output element is ON.

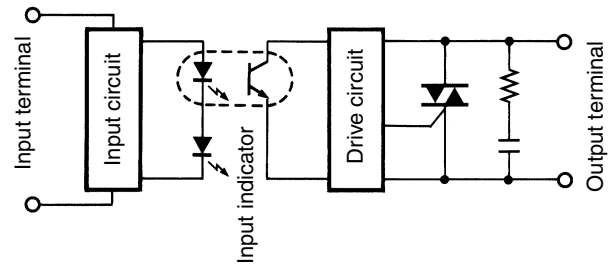

2-6 Heat Radiation Designing

(1) SSR Heat Radiation

Triacs, thyristors, and power transistors are semiconductors that can be used for an SSR output circuit. These semiconductors have a residual voltage internally when the SSR is turned ON. This is called output-ON voltage drop. If the SSR has a load current, the Joule heating of the SSR will result consequently. The heating value P (W) is obtained from the following formula.

Heating value P (W) = Output-ON voltage drop (V) x Carry current (A)

For example, if a load current of 8 A flows from the G3NA-210B, the following heating value will be obtained.

$$P = 1.6 \text{ V} \times 8 \text{ A} = 12.8 \text{ W}$$

If the SSR employs power MOS FET for SSR output, the heating value is calculated from the ON-state resistance of the power MOS FET instead.

In that case, the heating value P (W) will be obtained from the following formula.

$$P \text{ (W)} = \text{Load current}^2 \text{ (A)} \times \text{ON-state resistance } (\Omega)$$

If the G3RZ with a load current of 0.5 A is used, the following heating value will be obtained.

$$P \text{ (W)} = 0.5^2 \text{ A} \times 2.4 \Omega = 0.6 \text{ W}$$

The ON-state resistance of a power MOS FET rises with an increase in the junction temperature of a power MOS FET. Therefore, the ON-state resistance varies while the SSR is in operation. If the load current is 80% of the load current or higher, as a simple method, the ON-state resistance will be multiplied by 1.5.

$$P \text{ (W)} = 1^2 \text{ A} \times 2.4 \Omega \times 1.5 = 3.6 \text{ W}$$

The SSR in usual operation switches a current of approximately 5 A with no heat sink used. If the SSR must switch a higher current, a heat sink will be required. The higher the load current is, the larger the heat sink size will be. If the switching current is 10 A or more, the size of the SSR with a heat sink will exceed a single mechanical relay. This is a disadvantage of SSRs for circuit downsizing purposes.

(2) Heat Sink Selection

SSR models with no heat sinks incorporated (i.e., the G3NA, G3NE, and three-phase G3PB) need external heat sinks. When using any of these SSRs, select an ideal combination of the SSR and heat sink according to the load current.

The following combinations are ideal, for example.

G3NA-220B: Y92B-N100

G3NE-210T(L): Y92B-N50

G3PB-235B-3H-VD: Y92B-P200

A standard heat sink equivalent to an OMRON-made one can be used, on condition that the thermal resistance of the heat sink is lower than that of the OMRON-made one.

For example, the Y92B-N100 has a thermal resistance of 1.63°C/w.

If the thermal resistance of the standard heat sink is lower than this value (i.e., 1.5°C/w, for example), the standard heat sink can be used for the G3NA-220B.

Thermal resistance indicates a temperature rise per unit (W). The smaller the value is, the higher the efficiency of heat radiation will be.

(3) Calculating Heat Sink Area

An SSR with an external heat sink can be directly mounted to control panels under the following conditions.

- If the heat sink is made of steel used for standard panels, do not apply a current as high as or higher than 10 A, because the heat conductivity of steel is less than that of aluminum. Heat conductivity (in units of $\text{W} \cdot \text{m} \cdot ^\circ\text{C}$) varies with the material as described below.

Steel: 20 to 50

Aluminum: 150 to 220

The use of an aluminum-made heat sink is recommended if the SSR is directly mounted to control panels. Refer to the data sheet of the SSR for the required heat sink area.

- Apply heat-radiation silicon grease or a heat conductive sheet between the SSR and heat sink. There will be a space between the SSR and heat sink attached to the SSR. Therefore, the generated heat of the SSR cannot be radiated properly without the grease. As a result, the SSR may be overheated and damaged or deteriorated.

(4) Control Panel Heat Radiation Designing

Control equipment using semiconductors will generate heat, regardless of whether SSRs are used or not. The failure rate of semiconductors greatly increases when the ambient temperature rises. It is said that the failure rate of semiconductors will be doubled when the temperature rises 10°C.

Therefore, it is absolutely necessary to suppress the interior temperature rise of the control panel in order to ensure the long, reliable operation of the control equipment. In this respect, it can be said that the installation of a cooling fan is inevitable.

Heat-radiating devices in a wide variety exists in the control panel. As a matter of course, it is necessary to consider the total temperature rise as well as local temperature rise of the control panel. The following description provides information on the total heat radiation designing of the control panel.

As shown below, the heat conductivity Q will be obtained from the following formula, provided that t_h and t_c are the temperature of the hot fluid and that of the cool fluid separated by the fixed wall.

$$Q = k (t_h - t_c) A$$

Where, k is an overall heat transfer coefficient ($\text{W}/\text{m}^2\text{C}$). This formula is called a formula of overall heat transfer.

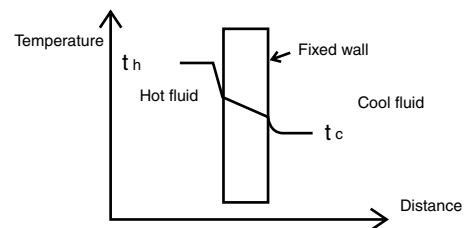

When this formula is applicable to the heat conductivity of the control panel under the following conditions, the heat conductivity Q will be obtained as shown below.

Average rate of overall heat transfer of control panel: k ($\text{W}/\text{m}^2\text{C}$)

Internal temperature of control panel: T_h ($^\circ\text{C}$)

Ambient temperature: T_c ($^\circ\text{C}$)

Surface area of control panel: S (m^2)

$$Q = k \times (T_h - T_c) \times S$$

The required cooling capacity is obtained from the following formula under the following conditions.

Desired internal temperature of control panel: T_h ($^\circ\text{C}$)

Total internal heat radiation of control panel: P_1 (W)

Required cooling capacity: P_2 (W)

$$P_2 = P_1 - k \times (T_h - T_c) \times S$$

The overall heat transfer coefficient k of a standard fixed wall in a place with natural air ventilation will be 4 to 12 ($\text{W}/\text{m}^2\text{C}$). In the case of a standard control panel with no cooling fan, it is an empirically known fact that a coefficient of 4 to 6 ($\text{W}/\text{m}^2\text{C}$) is practically applicable. Based on this, the required cooling capacity of the control panel is obtained as shown below.

Example

- Desired internal temperature of control panel: 40°C
- Ambient temperature: 30°C

- Control panel size 2.5 × 2 × 0.5 m (W × H × D)
Self-sustained control panel (with the bottom area excluded from the calculation of the surface area)
 - SSR: 20 G3PA-240B Units in continuous operation at 30 A.
 - Total heat radiation of all control devices except SSRs: 500 W
- $P1 = \text{Output-ON voltage drop } 1.6 \text{ V} \times \text{Load current } 30 \text{ A} \times 20 \text{ SSRs} + \text{Total heat radiation of all control devices except SSRs} = 960 \text{ W} + 500 \text{ W} = 1460 \text{ W}$

Heat radiation Q from control panel: Q

$Q2 = \text{Rate of overall heat transfer } 5 \times (40^\circ\text{C} - 30^\circ\text{C}) \times (2.5 \text{ m} \times 2 \text{ m} \times 2 + 0.5 \text{ m} \times 2 \text{ m} \times 2 + 2.5 \text{ m} \times 0.5 \text{ m}) = 662.5 \text{ W}$

Therefore, the required cooling capacity P2 will be obtained from the following formula.

$P2 = 1,460 - 663 = 797 \text{ W}$

Therefore, heat radiation from the surface of the control panel is insufficient. More than a heat quantity of 797 W needs to be radiated outside the control panel.

Usually, a ventilation fan with a required capacity will be installed. If the fan is not sufficient. An air conditioner for the control panel will be installed. The air conditioner is ideal for the long-time operation of the control panel because it will effectively dehumidify the interior of the control panel and eliminate dust gathering in the control panel.

Axial-flow fan: OMRON's R87B, R87F, and R87T Series
Air conditioner for control panel: Apiste's ENC Series

(5) Types of Cooling Device

Axial-flow Fans (for Ventilation)

These products are used for normal types of cooling and ventilation. OMRON's Axial-flow Fan lineup includes the R87F and R87T Series.



Heat Exchangers

Heat exchangers dissipate the heat inside control panels along heat pipes. Using a heat exchanger enables the inside and outside of the control panel to be mutually isolated, allowing use in locations subject to dust or oil mist.

Note OMRON does not produce heat exchangers.



Air Conditioners for Control Panels

Not only do these products offer the highest cooling capacity, they also offer resistance to dust and humidity by mutually isolating the inside and outside of the control panel.



Note OMRON does not produce air conditioners for control panels.

3 Mounting and Installation

3-1 Operation

(1) Leakage Current

A leakage current flows through a snubber circuit in the SSR even when there is no power input. Therefore, always turn OFF the power to the input or load and check that it is safe before replacing or wiring the SSR.

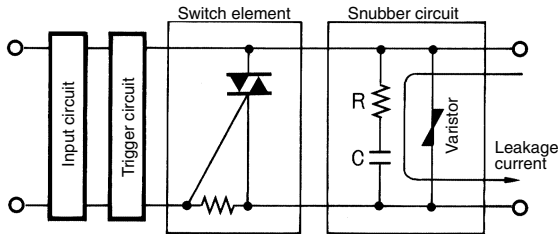

(2) Screw Tightening Torque

Tighten the SSR terminal screws properly. If the screws are not tight, the SSR will be damaged by heat generated when the power is ON. Perform wiring using the tightening torque shown in the following table.

- SSR Terminal Screw Tightening Torque

Screw size	Recommended tightening torque
M3.5	0.78 to 1.18 N • m
M4	0.98 to 1.37 N • m
M5	1.57 to 2.35 N • m
M6	3.92 to 4.9 N • m
M8	8.82 to 9.8 N • m

(3) SSR Mounting Panel Quality

If G3NA or G3NE SSRs are to be mounted directly onto the control panel, without the use of a heat sink, be sure to use a panel material with low thermal resistance such as aluminum or steel. Do not mount the SSR on a panel with high thermal resistance such as a panel coated with paint. Doing so will decrease the radiation efficiency of the SSR, causing heat damage to the SSR output element. Do not mount the SSR on a panel made of wood or any other flammable material. Otherwise the heat generated by the SSR will cause the wood to carbonize, and may cause a fire.

(4) Surface-mounting Socket

- Make sure that the surface-mounting socket screws are tightened securely when mounted. If the Unit is subjected to shock or vibration and the socket mounting screws are loose, the Socket and the SSR, or the lead wires may detach. The surface-mounting Sockets can be snapped on to the 35-mm DIN Track.
- Use a holding bracket to ensure proper connection between the SSR and Socket. Otherwise the SSR may detach from the socket if an excessive vibration or shock is applied.

(5) SSR Mounting and Dismounting Direction

Mount or dismount the SSR from the Socket perpendicular to the Socket surface. If it is mounted or dismounted with an inclination from the diagonal line, terminals of the SSR may bend and the SSR may not be properly inserted in the Socket.

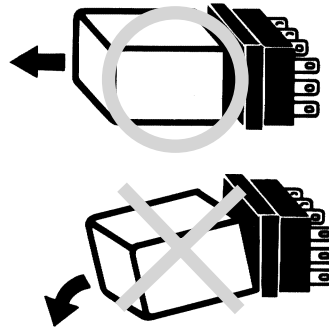

(6) Wiring for Wrapping Terminal Socket

Refer to the following table and conduct wiring properly. Improper wiring may cause the lead wires to detach.

Model	Wrapping type	Model (bit)	Applicable wires		Sheath length to be removed (mm)	Number of effective turns	Standard terminal (mm)	Draw-out force (kg)	Applicable sleeve
			AWG	Dia.					
PY□QN	Single-turn wrapping of sheathed line	21-A	26	0.4	43 to 44	Approx. 6	1 x 1	3 to 8	1-B
		22-A	24	0.5	36 to 37	Approx. 6		4 to 13	2-B
		23-A	22	0.65	41 to 42		4 to 15	20-B	
PT□QN	Normal wrapping	20-A	20	0.8	37 to 38	Approx. 4	1.0 x 1.5	5 to 15	

Note The PY□QN uses a 0.65-mm-dia. wire that can be turned six times.
The PT□QN uses a 0.8-mm-dia. wire that can be turned four times.

(7) Tab Terminal Soldering Precautions

Do not solder the lead wires to the tab terminal. Otherwise the SSR (e.g., G3NE) components will be damaged.

(8) Cutting Terminals

Do not cut the terminal using an auto-cutter. Cutting the terminal with devices such as an auto-cutter may damage the internal components.

(9) Deformed Terminals

Do not attempt to repair or use a terminal that has been deformed. Otherwise excessive force will be applied to the SSR, and it will lose its original performance capabilities.

(10) Hold-down Clips

Exercise care when pulling or inserting the hold-down clips so that their form is not distorted. Do not use a clip that has already been deformed. Otherwise excessive force will be applied to the

SSR, causing it not to perform to its full capacity, and also it will not have enough holding power, causing the SSR to be loose, and resulting in damage to the contacts.

(11) Ultrasonic Cleaning

Do not use ultrasonic cleaning. If the SSR is cleaned using ultrasonic cleaning after it has been mounted to the PCB, resonance due to ultrasonic waves may result in damage to the SSR's internal components.

(12) Terminal Arrangements and Internal Connections

1. Bottom View

As shown below, the bottom view of the terminal arrangement of the SSR is shown only if the terminals are not visible from the top side.

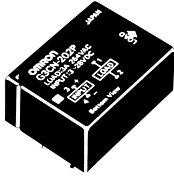

2. Rotating Direction of Bottom View

The terminal arrangement printed on the top side reflects the actual terminal arrangement that will be seen when the bottom is upside with the SSR rotated in the direction shown by the arrow with the direction mark (coil side) located on the left-hand side.

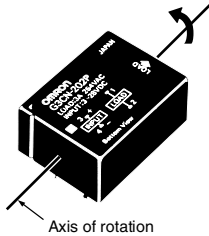

3-2 Panel Mounting

If SSRs are mounted inside an enclosed panel, the radiated heat of the SSR will stay inside, thus not only dropping the carry-current capacity of the SSRs but also adversely affecting other electronic device mounted inside. Open some ventilation holes on the upper and lower sides of the control panel before use.

The following illustrations provide a recommended mounting example of G3PA Units. They provide only a rough guide and so be sure to confirm operating conditions using the procedure detailed in (4) Confirmation after Installation on page 33.

(1) SSR Mounting Pitch

Panel Mounting

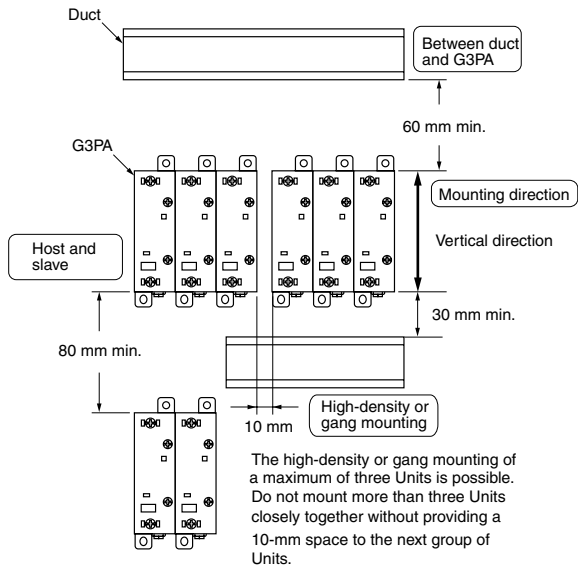

(2) Relationship between SSRs and Ducts

Duct Depth

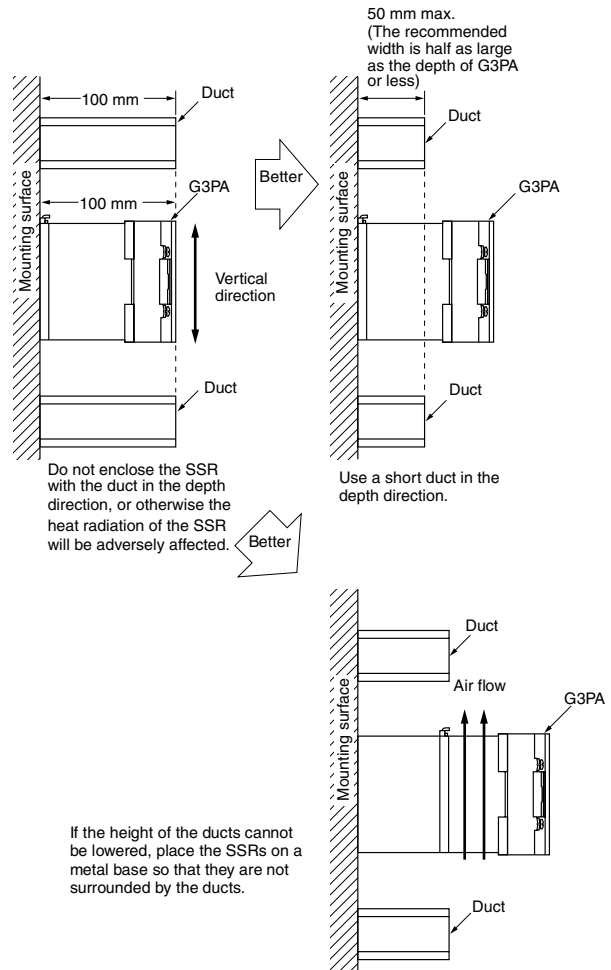

(3) Ventilation

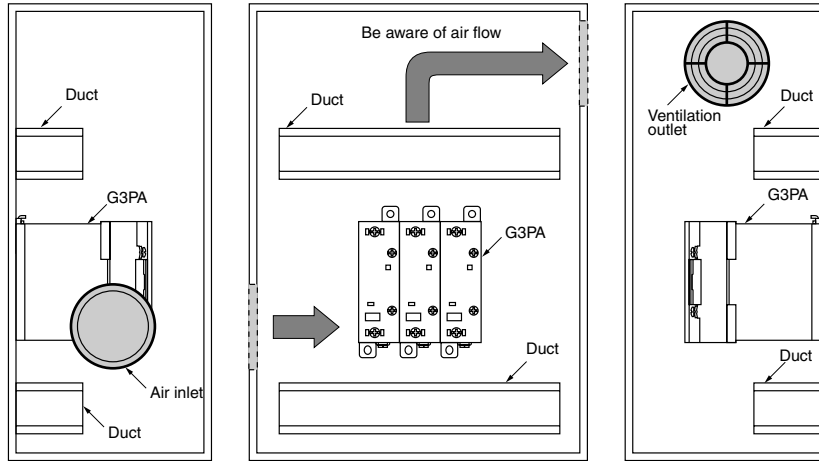

If the air inlet or air outlet has a filter, clean the filter regularly to prevent it from clogging and ensure an efficient flow of air.

Do not locate any objects around the air inlet or air outlet, or otherwise the objects may obstruct the proper ventilation of the control panel.

A heat exchanger, if used, should be located in front of the G3PA Units to ensure the efficiency of the heat exchanger.

(4) Confirmation after Installation

The above conditions are typical examples confirmed by OMRON. The application environment may affect conditions and ultimately the ambient temperature must be measured under power application to confirm that the load current-ambient temperature ratings are satisfied for each model.

Ambient Temperature Measurement Conditions

1. Measure the ambient temperature under the power application conditions that will produce the highest temperature in the control panel and after the ambient temperature has become saturated.
2. Refer to *Figure 1* for the measurement position. If there is a duct or other equipment within the measurement distance of 100 mm, refer to *Figure 2*. If the side temperature cannot be measured, refer to *Figure 3*.

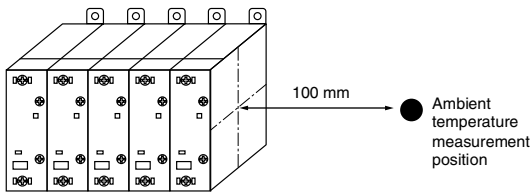

Figure 1: Basic Measurement Position for Ambient Temperature

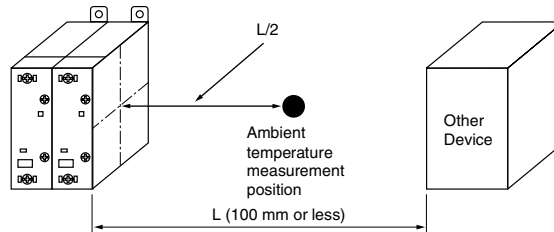

Figure 2: Measurement Position when a Duct or Other Device is Present

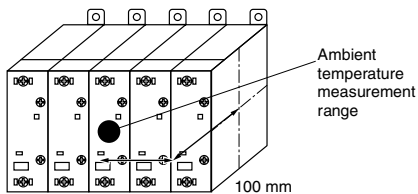

Figure 3: Measurement Position when Side Temperature Cannot be Measured

3. If more than one row of SSRs are mounted in the control panel, measure the ambient temperature of each row, and use the position with the highest temperature.

Consult your OMRON dealer, however, if the measurement conditions are different from those given above.

3-3 Operation and Storage Environment Precautions

(1) Ambient Temperature (Operating)

The rated operating ambient temperature of an SSR is determined proper ventilation. If the heat radiation conditions of the SSR, such as fresh air supply or ventilation is improper, the operating ambient temperature will exceed the rated value. As a result, the SSR will fail to operate or burn out.

When using SSRs, check that the circuits are designed to satisfy the conditions specified under *Load Currents vs. Ambient Temperatures*.

Be aware that the operating ambient temperature will be excessive, depending on the environmental conditions (e.g., weather and indoor air-conditioning conditions) or operating conditions (e.g., enclosed panel mounting).

(2) Operation and Storage Locations

Do not operate or store the SSR in the following locations. Doing so may result in malfunction or deterioration of performance specifications.

- Locations subject to direct sunlight.
- Locations subject to corrosive or flammable gases.
- Locations subject to dust (especially iron dust) or salts.
- Locations subject to shock or vibration.
- Locations subject to exposure to water, oil, or chemicals.

(3) Extended Storage of the SSR

If the SSR is stored for an extended period of time, the terminal will be exposed to the air, reducing its solderability due to such effects as oxidation. Therefore, when installing a Relay onto a board after a long time in storage, check the state of the solder before use.

(4) Vibration and Shock

Do not subject the SSR to excessive vibration or shock. Otherwise the SSR will malfunction and may cause damage to the internal components. To prevent the SSR from abnormal vibration, do not install the Unit in locations or by means that will subject it to the vibrations from other devices, such as motors.

(5) Solvents

Do not allow the SSR to come in contact with solvents such as thinners or gasoline. Doing so will dissolve the markings on the SSR.

(6) Oil

Do not allow the SSR terminal cover to come in contact with oil. Doing so will cause the cover to crack and become cloudy.

(7) Handling the SSR

Do Not Drop

The SSR is a high-precision component. Do not drop the SSR or subject it to excessive vibration or shock regardless of whether the SSR is mounted or not.

The maximum vibration and shock that an SSR can withstand varies with the model. Refer to the relevant datasheet.

The SSR cannot maintain its full performance capability if the SSR is dropped or subjected to excessive vibration or shock resulting in possible damage to its internal components.

The impact of shock given to the SSR that is dropped varies upon the case, and depends on the floor material, the angle of collision with the floor, and the dropping height. For example, if a single SSR is dropped on a plastic tile from a height of 10 cm, the SSR may receive a shock of 1,000 m/s² or more.

Handle the SSR models in in-line packages with the same care and keep them free from excessive vibration or shock.

3-4 PCB-mounting SSR

(1) Suitable PCB

1. PCB Material

PCBs are classified into epoxy PCBs and phenol PCBs. The following table lists the characteristics of these PCBs. Select one taking into account the application and cost. Epoxy PCBs are recommended for SSR mounting in order to prevent the solder from cracking.

Item	Epoxy		Phenol
	Glass epoxy	Paper epoxy	Paper phenol
Electrical characteristics	<ul style="list-style-type: none"> High insulation resistance. Highly resistive to moisture absorption. 	<ul style="list-style-type: none"> Inferior to glass epoxy but superior to paper phenol PCBs. 	<ul style="list-style-type: none"> New PCBs are highly insulation-resistive but easily affected by moisture absorption and cannot maintain good insulation performance over a long time.
Mechanical characteristics	<ul style="list-style-type: none"> The dimensions are not easily affected by temperature or humidity. Ideal for through-hole or multi-layer PCBs. 	<ul style="list-style-type: none"> Inferior to glass epoxy but superior to paper phenol PCBs. 	<ul style="list-style-type: none"> The dimensions are easily affected by temperature or humidity. Not suitable for through-hole PCBs.
Economical efficiency	<ul style="list-style-type: none"> Expensive 	<ul style="list-style-type: none"> Rather expensive 	<ul style="list-style-type: none"> Inexpensive
Application	Applications that require high reliability.	Applications that may require less reliability than those for glass epoxy PCBs but require more reliability than those of paper phenol PCBs.	Applications in comparatively good environments with low-density wiring.

2. PCB Thickness

The PCB may warp due to the size, mounting method, or ambient operating temperature of the PCB or the weight of parts mounted to the PCB. Should warping occur, the internal mechanism of the SSR on the PCB will be deformed and the SSR may not provide its full capability. Determine the thickness of the PCB by taking the material of the PCB into consideration.

3. Terminal Hole and Land Diameters

Refer to the following table to select the terminal hole and land diameters based on the SSR mounting dimensions. The land diameter may be smaller if the land is processed with through-hole plating.

Hole dia. (mm)		Minimum land dia. (mm)
Nominal value	Tolerance	
0.6	±0.1	1.5
0.8		1.8
1.0		2.0
1.2		2.5
1.3		2.5
1.5		3.0
1.6		3.0
2.0		3.0

(2) Mounting Space and Direction

The ambient temperature around the sections where the SSR is mounted must be within the permissible ambient operating temperature. If two or more SSRs are mounted closely together, the SSRs may radiate excessive heat. Therefore, make sure that the SSRs are separated from one another at the specified distance provided in the datasheet. If there is no such provision, maintain a space that is as wide as a single SSR.

Provide adequate ventilation to the SSRs as shown in the following.

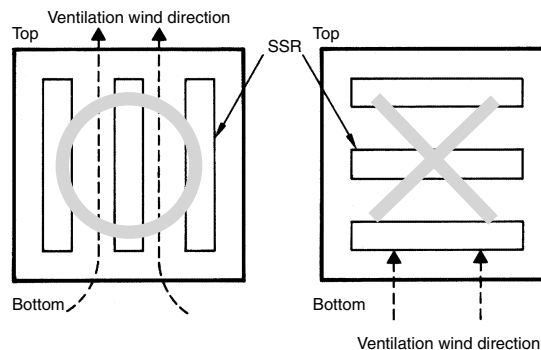

(3) Mounting SSR to PCB

Read the precautions for each model and fully familiarize yourself with the following when mounting the SSR to the PCB.



Step 1
SSR mounting

1. Do not bend the terminals to make the SSR self-standing, otherwise the full performance of the SSR may not be possible.
2. Process the PCB properly in accordance with the mounting dimensions.

Step 5
Cooling

1. After soldering the SSR, be sure to cool down the SSR so that the soldering heat will not deteriorate the SSR or any other component.
2. Do not dip the SSR into cold liquid, such as a detergent, immediately after soldering the SSR.

Step 2
Flux coating

1. The flux applied must be non-corrosive rosin flux, which is suitable to the material of the SSR. Apply alcohol solvent to dissolve the flux.
2. Make sure that all parts of the SSR other than the terminals are free of the flux. The insulation resistance of the SSR may be degraded if the flux is on the bottom of the SSR.

Step 6
Cleaning

1. Refer to the following table for the selection of the cleaning method and detergent.

Detergent

Boiling cleaning or dip cleaning is available to the SSR. Do not perform ultrasonic cleaning or cut the terminals, otherwise the internal parts of the SSR may be damaged. Make sure that the temperature of the detergent is within the permissible ambient operating temperature of the SSR.

2. Availability of Detergents

Detergent		Availability
Aqueous detergent	Indusco Holys Pure water (pure hot water)	OK
Alcohol	IPA Ethanol	OK
Others	Paint thinner Gasoline	NG

- Note:**
1. Contact your OMRON representatives before using any other detergent. Do not apply Freon TMC, paint thinner, or gasoline to any SSR.
 2. If detergent is used, confirm that there is no corrosion in the SSR terminals, even after long term use.

Step 3
Preheating

1. Be sure to preheat the SSR to allow better soldering.
2. Preheat the SSR under the following conditions.

Temperature	100°C max.
Time	1 m max.

3. Do not use the SSR if it is left at high temperature over a long time. This may change the characteristics of the SSR.

Step 4
Soldering

Automatic Soldering

1. Flow soldering is recommended for maintaining a uniform soldering quality.
 - Solder: JIS Z3282 or H63A
 - Soldering temperature: Approx. 250°C (260°C for DWS)
 - Soldering time: Approx. 5 s max. (Approx. 2 s for first time and approx. 3 s for second time for DWS)
 - Perform solder level adjustments so that the solder will not overflow on the PCB.

Manual Soldering

1. After smoothing the tip of the soldering iron, solder the SSR under the following conditions.
 - Solder: JIS Z3282, 1160A, or H63A with rosin-flux-cored solder
 - Soldering iron: 30 to 60 W
 - Soldering temperature: 280°C to 300°C
 - Soldering time: Approx. 3 s max.
2. As shown in the above illustration, solder with a groove for preventing flux dispersion is available.

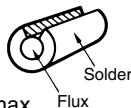

Step 7
Coating

1. Do not fix the whole SSR with resin, otherwise the characteristics of the SSR may change.
2. The temperature of the coating material must be within the permissible ambient operating temperature range.

Coating

Type	Availability
Epoxy	OK
Urethane	OK
Silicone	OK

Actions are being taken worldwide to stop the use of CFC-113 (chlorofluorocarbon) and 1,1,1 trichloroethane. Your understanding and cooperation are highly appreciated.

4 SSR Reliability

4-1 Failure Rate and Life Expectancy

It is said that the failure rate of an electronic component or product can be expressed by a bathtub curve.

- Decreasing failure rate: Early failure period (e.g. design or manufacturing fault)
- Constant failure rate: Random failure period
- Increasing failure rate: Wear and tear failure period

Semiconductors such as triacs or thyristors are used for SSR output and so the SSR is not subject to mechanical wear. Therefore, the life expectancy of the SSR depends on the failure rate of internal components. For example, the rate for the G3M-202P is 321 Fit (1 Fit = 10^{-9} = λ (malfunctions/time)). The MTTF calculated from this value is as follows:

$$\text{MTTF} = 321 / \lambda_{60} = 3.12 \times 10^6 \text{ (time)}$$

With the SSR, however, unlike a single semiconductor, even if it is used correctly, heat-stress resulting from changes in the ambient temperature or heat generated by the SSR itself may have several adverse effects, such as deterioration in the solder in components or a drop in the illumination efficiency of the built-in coupler's LED, and may result in failure. These factors will determine the actual lifetime of the SSR. With OMRON SSRs, we estimate that these failures due to deterioration will start to occur after approximately 10 years, but this figure may vary with the ambient conditions.

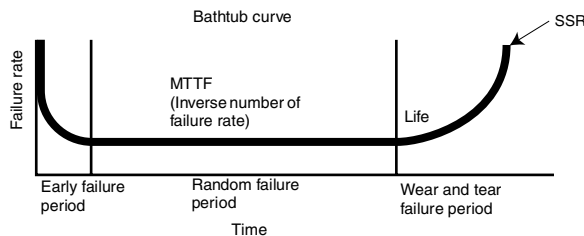

4-2 Quality and Reliability

From a viewpoint of quality control, the quality of a product refers to the quality of the manufacturing stages or the initial quality of the product. Usually, the quality of the product does not include any time factor. The reliability of a product refers to the probability of the product demonstrating required functions under specified conditions while the product is in service.

In plain words, a product with high reliability means that the product is tough and serviceable for a long time.

OMRON evaluates SSRs with their quality (initial performance) and reliability. The noise resistance of SSRs is, for example, checked as an initial performance test item. SSRs will malfunction whenever the SSRs are interfered with excessive noise. The repetitive inrush current (surge) resistance of SSRs is checked as a reliability test item to evaluate the secular changes of the SSRs with repetitive surges.

4-3 Reliability Test

OMRON conducts the following reliability tests on SSRs.

- Mechanical performance tests: Vibration, shock, terminal strength, and drop tests.
- Environmental tests: High-temperature operating, high-temperature storage, low-temperature storage, high-temperature and high-humidity storage, thermal shock, intermittent current-carrying, and repetitive surge tests.

The following items of electrical characteristic data are checked before and after the tests: Must-operate voltage, reset voltage, leakage current, output-ON voltage drop, zero-cross voltage, loss time, operate time, release time, noise resistance, shock resistance, dielectric strength, and insulation resistance.

4-4 Noise Test

The noise test of an SSR is conducted with a noise simulator. The SSR is designed to withstand 100-ns and 1- μ s noise at 1,500 V AC and 10 times as high as the rated DC voltage. (Some older models are tested at 1,200 V.)

The noise resistance of an SSR is checked with the SSR malfunctioning with noise interference.

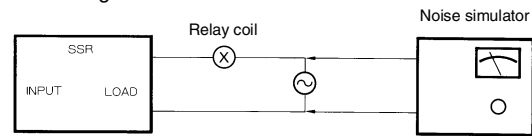

4-5 Dielectric Strength and Insulation Resistance

Like other electrical appliances, the dielectric strength and the insulation resistance of the insulated part of SSRs are checked for the prevention of electric shocks or fires that may result from the deterioration of the insulated part. The following items are checked.

Input terminals and output terminals: The whole input terminals are short-circuited to the whole output terminals with voltage imposed between them.

Input and output terminals and heat sink (if used): The whole input and output terminals are short-circuited together and voltage is imposed between the heat sink and the whole terminals.

(1) Input terminals and output terminals

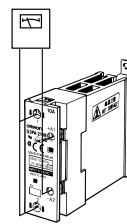

(2) Input and output terminals and heat sink

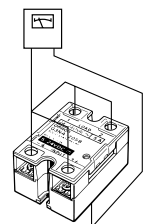
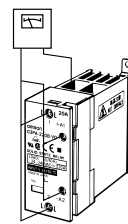
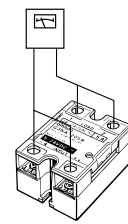

4-6 Dielectric Strength of Internal Elements

The dielectric strength of the internal output elements of SSRs is two or three times as high as the rated supply voltage. In addition, with a snubber circuit employed, the SSR has immunity from external noise. Refer to the following dielectric strength values of triacs, for example.

- SSR for 100-V load power supply: 400 V min.
- SSR for 200-V load power supply: 600 V min.
- SSR for 400-V load power supply: 1000 V min.
- SSR for 480-V load power supply: 1200 V min.

5 Q&A

■ Q1. What is the zero cross function?

The zero cross function turns ON the SSR when the AC load voltage is close to 0 V, thus suppressing the noise generation of the load current when the load current rises quickly.

The generated noise will be partly imposed on the power line and the rest will be released in the air. The zero cross function effectively suppresses both noise paths.

A high inrush current will flow when the lamp is turned ON, for example. When the zero cross function is used, the load current

always starts from a point close to 0 V. This will suppress the inrush current more than SSRs without the zero cross function.

It is ideal for the load current to start from 0 V when the zero cross function is used. Due to circuit restrictions, however, the load current will start from a point that is 0 ± 20 V. The difference in voltage between this point and the 0 V point is called zero cross voltage.

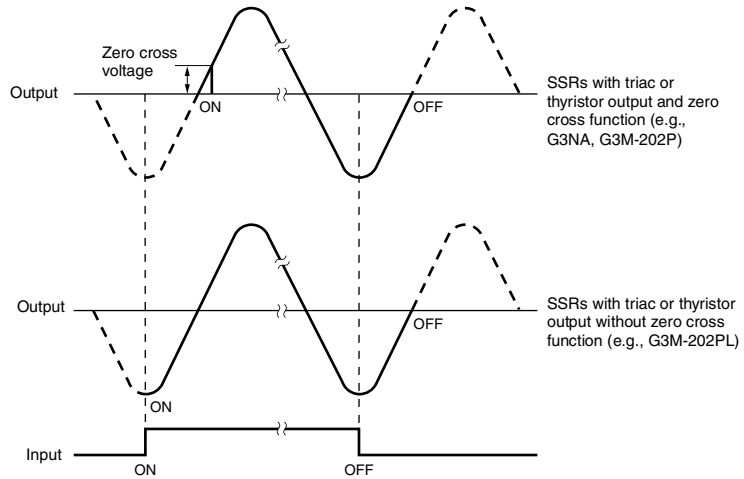
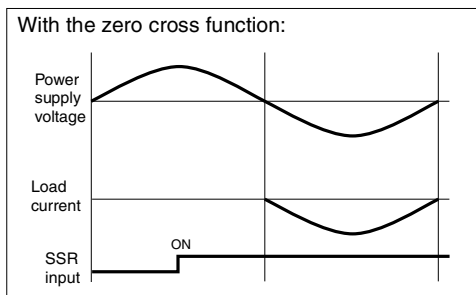
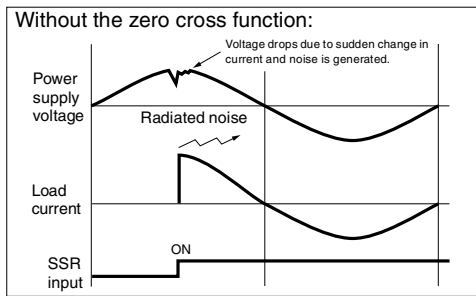

Zero Cross

■ Q2. Why does the input current vary with the SSR?

An SSR with photocoupler isolation has a different input current from an SSR with phototriac isolation.

An SSR with a zero cross function with photocoupler isolation does not require a high input current because the photocoupler

ensures efficient signal transmission. The SSR, however, requires a drive circuit of complicated construction.

Photocoupler input current < Phototriac input current

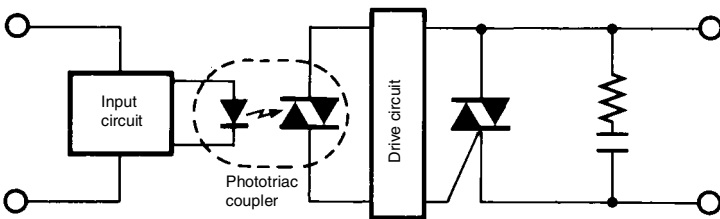
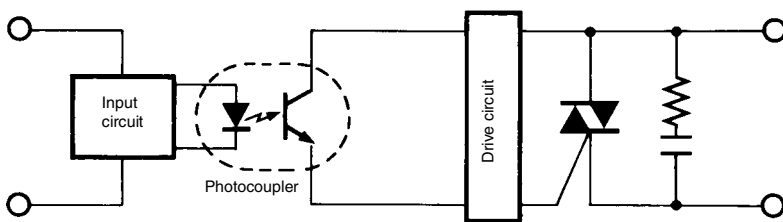

Zero Cross, Photocoupler, and Phototriac

Q3. What is the difference in switching with a thyristor and a triac?

There is no difference between them as long as resistive loads are switched. For inductive loads, however, thyristors are superior to triacs due to the back-to-back connection of the thyristors. For the switching element, an SSR uses either a triac or a pair of thyristors connected back-to-back.

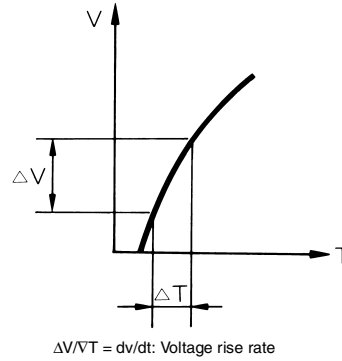
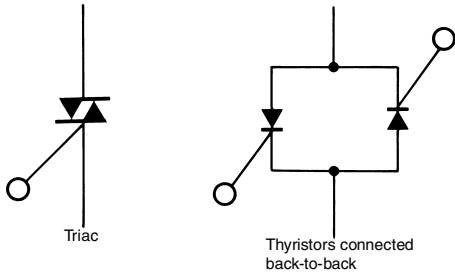

There is a difference between thyristors and triacs in response time to rapid voltage rises or drops. This difference is expressed by dv/dt (V/ μ s) (Refer to Q5 on page 39). This value of thyristors is larger than that of triacs. Triacs can switch inductive motor loads that are as high as 3.7 kW. Furthermore, a single triac can be the functional equivalent of a pair of thyristors connected back-to-back and can thus be used to contribute to downsizing SSRs.

	Resistive load		Inductive load	
	40 A max.	Over 40 A	3.7 kW max.	Over 3.7 kW
Triac	OK	OK	OK	Not as good
Two thyristors	OK	OK	OK	OK

Thyristors, Triacs, and dv/dt

Q4. What are the characteristics of thyristors and triacs?

Both triacs and thyristors turn ON and OFF to provide or stop power supply to loads to be controlled. SSRs for AC switching employ either triacs or thyristors. Unlike power transistors or power MOS FETs, triacs, and thyristors are semiconductor elements with no self-arc suppression. This means a current flows into triacs or thyristors that are turned

ON with a gate signal. The current cannot be, however, turned OFF when the gate signal turns OFF. The triacs and thyristors are kept ON until the output current is turned OFF. These semiconductor elements are easy to break when they are short-circuited. Be aware of these characteristics from a viewpoint of the safety when designing equipment or systems that employ SSRs.

Thyristors, Triacs, and Self-arc Suppressing

Q5. What is a snubber circuit?

When SSRs with triac or thyristor outputs are used to switch inductive loads, excessive voltage changes will occur within a short period when the triacs or thyristors are turned ON and OFF. As a result, the SSRs will malfunction (make mistakes in firing time). A snubber circuit is designed to suppress excessive voltage changes.

The characteristics of triacs or thyristors for excessive voltages are expressed by dv/dt . The limit value that turns ON these output semiconductor elements is called the critical rate-of-rise of the OFF-state voltage (or static dv/dt). The limit value that cannot turn OFF the output semiconductor elements is called commutation dv/dt .

A snubber circuit suppresses surge. If the surge voltage is high, however, the output semiconductor elements will be damaged. Therefore, when an SSR with no built-in surge absorbing element (i.e., a varistor) is used for an inductive load, for example, the SSR will need a surge suppressing measure other than the snubber circuit.

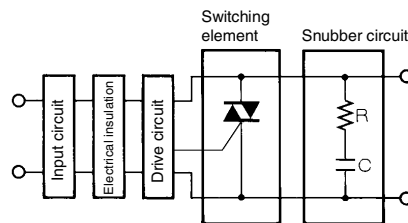
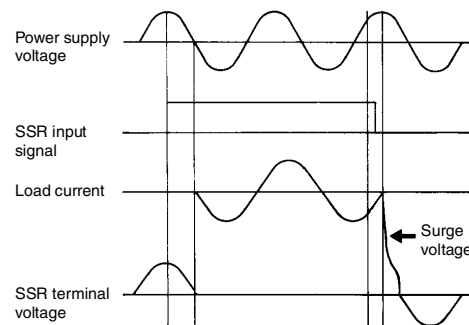

However a snubber circuit is the main cause of current leakage from an SSR. The relationship between the snubber circuit and current leakage is like balancing a seesaw. With the snubber effect increased, the leakage current will increase. With the leakage current suppressed, the SSR will be adversely affected by noise. OMRON selects the best snubber circuit constant for each model according to the rated current of the model.

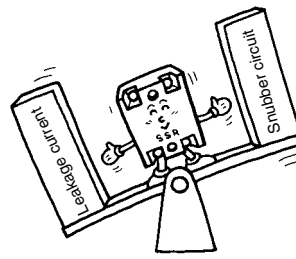

Static dv/dt, Commutation dv/dt, Snubber Circuits, and Leakage Current

Q6. What is a hybrid SSR?

A hybrid SSR is a relay that turns the load ON and OFF with a semiconductor element but uses a mechanical relay for normal operation. In other words, a hybrid SSR is a combination of an EMR (electromagnetic relay) and SSR.

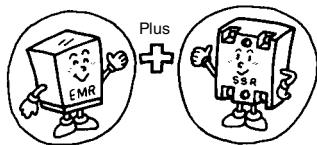

<p>EMR merits</p> <ul style="list-style-type: none"> • Excellent insulation • Excellent noise resistance • Multiple poles 	<p>Plus</p> <p>G9H</p>	<p>SSR merits</p> <ul style="list-style-type: none"> • High-frequency switching operations • No operation noise • Zero cross circuit
<ul style="list-style-type: none"> • Compact • Low heat radiation • Low cost 	<p>G9H Hybrid SSR</p>	<ul style="list-style-type: none"> • Long life

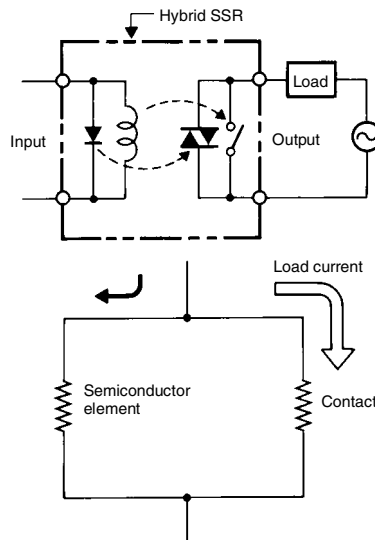

Principle of Operation

When the hybrid SSR input is turned ON, the triac turns ON and then the contact turns ON. At that time, the resistance of the contact will be lower than that of the triac, causing most of the load current to flow to the contact. When the SSR input is turned OFF, the contact and triac are turned OFF. The triac is turned OFF after the current to the contact is turned OFF, and therefore, no arc will result. This is the reason a hybrid SSR ensures a long service life.

Hybrid SSR

Q7. Are there any SSRs with normally closed contacts?

An SSR with a triac or thyristor output cannot have normally closed contacts unless a drive power supply is employed. To use normally closed contacts, the output semiconductors need to be normally closed. Therefore, depression-type transistors must be used for the semiconductor element. Recently, SSRs that have normally closed contacts with depression-type power MOS FETs have been sold for minute signal switching purposes. OMRON's G3VM is one of them.

Depression-type and Enhancement-type

“Depression-type” refers to types for which a drain current flows even when the gate voltage is set to 0 V with MOS FET, and “enhancement-type” refers to types for which a drain current will not flow unless the gate voltage is greater than 0 V.

Depression-type, Enhancement-type, and Normally Closed Contacts

Q8. What is the soft start function?

The soft start function increases the AC output of SSRs gradually to 100% using phase control. This suppresses the inrush current

of the load power supply that results when the load power supply is turned ON, making it possible to start the load smoothly. This

function can be used to effectively control motor and halogen lamp loads. A soft start function is incorporated in the G3PX Power Controller and the G3J-series SSRs for motor control.

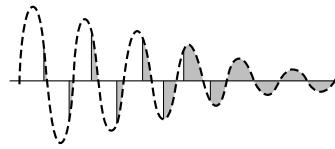

Soft Start Function

■ Q9. What do the model numbers mean?

The following model legend applies to OMRON's SSRs.

G3-□□-□□□□□□□□□□-□□
 12 3 4 5 6 7 8 9

1. Product Classification

The prefix G indicates that the product is a relay.

2. Basic Model Code

The number 3 indicates that the product is an SSR.

3. A specific alphabetic character for the model.

4. A specific alphabetic character for the model.

5. Load Power Supply Voltage

Used only for series products and not for standard models.

1: Maximum operating voltage is 100 to 200 VAC or DC.

2: Maximum operating voltage is 200 to 300 VAC or DC.

4: Maximum operating voltage is 400 to 500 VAC or DC.

6. Load Current

Indicates the maximum load current.

Example: 000075: 75 A

000150: 150 A

00R5: 0.5 A

0010: 10 A

7. Terminal Shape

B: Screw terminals

P: PCB terminals

S: Plug-in terminals (for special sockets)

T: Tab terminals

8. Zero Cross Function

None: Yes

L: No

9. Suffix Code

A code specifying a series product, approved standards, or specific characteristics such as the number of elements.

For the G3NA-220B, for example, the load power supply voltage is 200 V, the load current is 20 A, the zero cross function and screw terminals are provided. For the G3M-102PL, the load power supply voltage is 100 V, the load current is 2 A, the zero cross function is not provided, and PCB terminals are provided.

Model Legend

■ Q10. What is the difference between recommended values and rated values?

The maximum load current of an SSR is determined on the assumption that the SSR is used independently connected to a resistive load.

The expected actual operating conditions of the SSR are, however, tougher due to the fluctuation of the power supply voltage or the panel space. The recommended values of the SSR are pro-

vided in consideration of a 20% to 30% safety margin based on the rated values.

A larger safety margin will be required if an inductive load, such as a transformer or motor, is used due to the inrush current that will flow.

Recommended Loads

■ Q11. What is the counter-electromotive force?

Counter-electromotive force is generated from an inductive load that uses a coil when the load is turned OFF.

As shown below, magnetic flux is generated when voltage is applied to a coil.

When the switch is turned OFF, the magnetic flux will disappear. Due to the self-induction of the coil, counter-electromotive force will be generated in the direction required to maintain the magnetic flux even though the switch is already closed. Therefore, the counter-electromotive force has no way to escape, and a very high voltage is generated.

The counter-electromotive force may cause contact friction damage and fatal element damage. Pay utmost attention when using coil loads. As shown below, the power supply voltage and counter-electromotive force will be imposed on the closed switch.

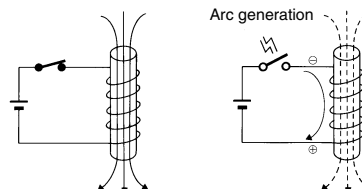

Counter-electromotive Force

■ Q12. What is the meaning of I^2t for fuse selection?

When a fuse is connected to an SSR, the I^2t of the SSR is the integral value of an inrush current that flows for a specified time from the fuse into the SSR when the SSR is turned ON.

The following table provides permissible I^2t values for the respective SSRs. When using a high-speed breaking fuse for an SSR, check that the I^2t is the same as or less than the specified value.

I^2t Values

G3NA-210B	121A ² s
G3NA-220B	260A ² s
G3NA-240B	2660A ² s

Fuse and I^2t

■ Q13. Why does the operating time vary between AC inputs and DC inputs?

An SSR with an AC input has a rectification circuit. A capacitor is included in the rectification circuit. The operating time of the SSR will be slower than an SSR with a DC input due to the charge time of the capacitor.

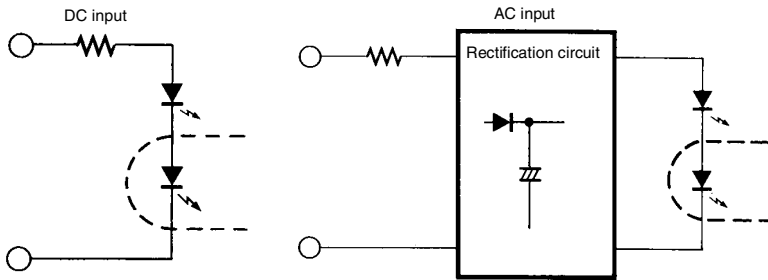

Operating Time

■ Q14. What is the relationship between the leakage current and load voltage?

The leakage current of an SSR increases in proportion to the load voltage. The following graphs show typical examples of the leakage currents and load voltages of SSRs.

G3FD-102SN Rating: 0.1 mA max. (100 V)

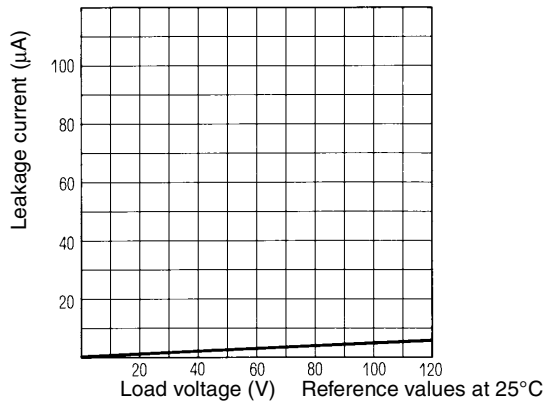

G3FD-X03SN Rating: 5 mA max. (50 V)

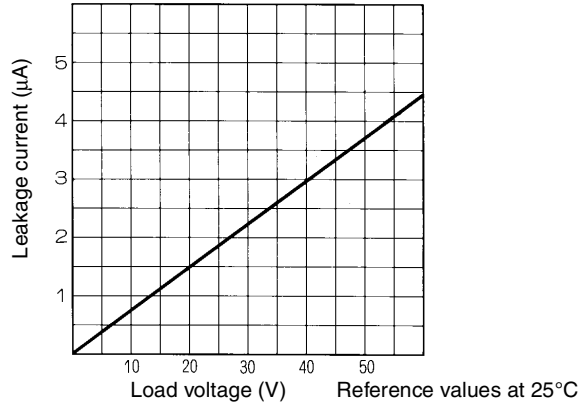

G3F-203SN Rating: 10 mA max. (200 V)

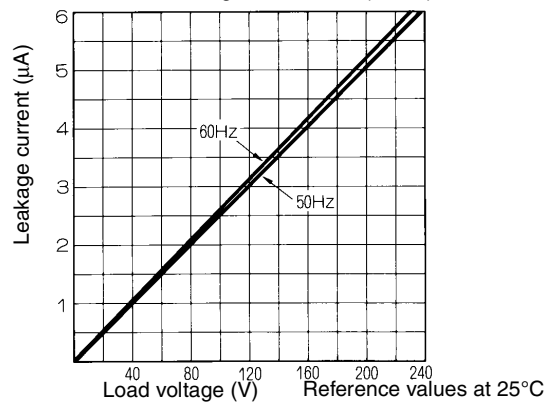

Leakage Current

■ Q15. Is it possible to connect SSRs in series?

Yes, it is. SSRs are connected in series mainly to prevent short circuit failures. Each SSR connected in series shares the burden of the surge voltage. Therefore, the SSRs are protected from overvoltage.

A high operating voltage, however, cannot be applied to the SSRs connected in series. The reason is that the SSRs cannot share the burden of the load voltage due to the difference between the SSRs in operating time and reset time when the load is switched.

Series Connections

■ Q16. Is it possible to connect two 200-VAC SSRs in series to a 400-VAC load?

No, it is not. The two SSRs are slightly different to each other in operating time. Therefore, 400 VAC will be imposed on the SSR with a longer operating time.

Series Connections

■ Q17. Is it possible to connect SSRs in parallel?

Yes, it is. SSRs are connected in parallel mainly to prevent open circuit failures. Usually, only one of the SSR is turned ON due to the difference in output ON voltage drop between the SSRs.

Therefore, it is not possible to increase the load current by connecting the SSRs in parallel.

If an ON-state SSR in operation is open, the other SSR will turn ON when the voltage is applied, thus maintaining the switching operation of the load.

Do not connect two or more SSRs in parallel to drive a load exceeding the capacity each SSRs; the SSRs may fail to operate.

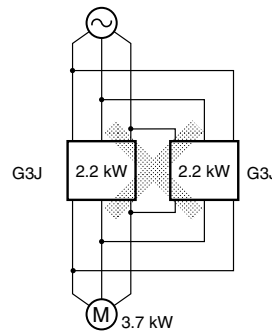

Parallel Connections

■ Q18. Is it possible to connect a DC output load to a negative electrode? Can either a positive or negative load be connected?

Any of the following connections will work. If the load has positive and negative polarities, be sure to connect the load with the polarities corresponding in the way shown below.

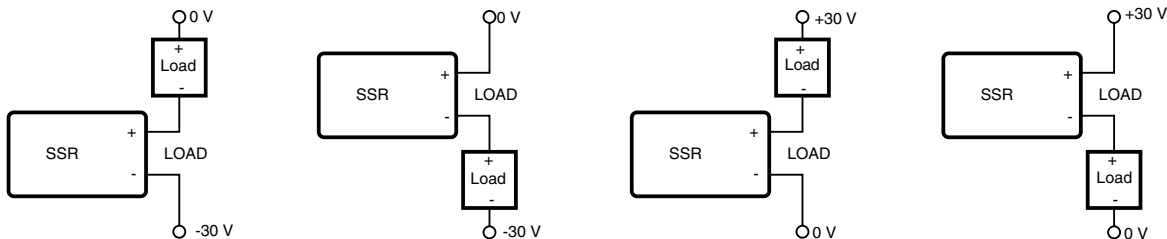

Negative Power Supply

■ Q19. What portion of the power factor of the load is practically applicable?

A power factor range between $\cos\phi = 1$ and about 0.4 is available. If the power factor is less than 0.4, the phase gap between the current and the voltage will become large, and even if the current becomes 0, an overvoltage state with a changing voltage will

occur. In this state, if dv/dt exceeds the allowable value for the SSR, the SSR will not be able to turn OFF, and the SSR will malfunction. (Refer to Q5 on page 39.)

Power Factor

■ Q20. Why is the minimum load current for most SSRs limited to 0.1 A?

Triac or transistor output elements have a minimum holding current. Considering the ambient operating temperature, the minimum load current based on the minimum holding current is 0.1 A. If the load current is less than 0.1 A, the output element cannot maintain the ON-status of the load. As a result, the output waveform may oscillate or may not turn ON.

Usually, an SSR operating at 200 V has a maximum leakage current of 10 mA. To prevent load reset failures caused by the leakage current, the minimum load current is limited to 0.1 A on the

assumption that the minimum reset current is 10% of the rated value.

Therefore, for example, if a load with a rated current of 50 mA is used, the leakage current with the SSR turned OFF will be 20% of the rated value. This may cause reset failures, depending on the load.

Two characteristics of SSRs with power MOS FET output elements (e.g., G3DZ, G3RZ), are that a holding current is unnecessary, and the leakage current is small. Switching is possible for loads as small as 100 μ A at 200 VAC.

Minimum Load Current

■ Q21. Why can most SSRs not switch micro-loads?

The minimum load current for which switching is possible with SSRs with power MOS FET outputs (G3DZ/RZ) is 100 μ A at 200 VAC, or 10 μ A or 100 μ A at 125 VDC. The minimum load currents for SSRs with triac or thyristor AC outputs and for SSRs with power transistor DC outputs are as detailed below.

SSRs with AC Outputs

Presently, the minimum load current of most SSRs is limited to 100 mA. At an ambient temperature of 25°C or higher, this value will be a maximum of 50 mA. There are two reasons for this. One is for the prevention of load reset failures that may be caused by current leakage. The other is for the holding current required by each SSR in operation.

A smaller micro-load can be connected to the SSR with a bleeder resistor connected in parallel with the load. MOS FET relays can solve the above problems by directly switching micro-loads without a bleeder resistor.

Bleeder Resistor Values

100 VAC	5 to 10 k Ω	3 W
200 VAC	5 to 10 k Ω	15 W

SSRs with DC Outputs

The leakage current of an SSR may cause load reset failures.

If the maximum leakage current of the SSR is 0.1 mA, the SSR can switch most micro-loads. If the G3CN-D or G3FD or G3HD is used, however, be aware that the leakage current is rather high. Use an appropriate bleeder resistor if reset failures are likely to result.

Refer to the following table for bleeder resistor values.

Bleeder Resistor Values

5 VDC	1.6 k Ω	1/4 W
12 VDC	620 Ω	1 W
24 VDC	330 Ω	5 W

MOS FET Relay, Micro-load, and Bleeder Resistor

■ Q22. Why does a relay make noise when switched with an SSR?

An SSR has a leakage current whether or not the input of the SSR is ON or OFF. If a small relay is driven by the SSR, the relay coil will be slightly energized. As a result, the relay will make noise.

This problem can be solved by connecting a bleeder resistor in parallel to the relay coil. If two or more relay coils are connected in parallel or the relay coil is connected to another load in parallel, an effect similar to the bleeder resistor can be produced.

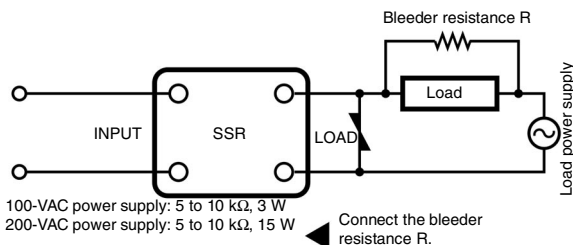

Bleeder Resistance

Q23. Why is the current not stable when the power supply is switched ON and OFF?

The power supply for an SSR is a capacitive load due to the built-in smoothing capacitance of the power supply. As clearly shown in the graph below, there are periods where almost no current flows and periods where the capacitance changes quickly.

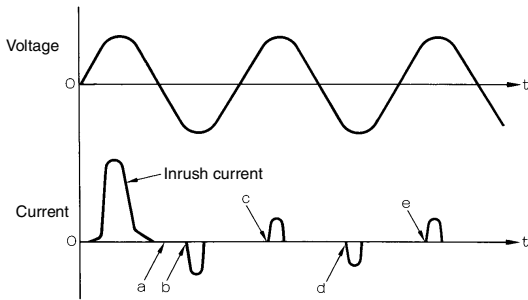

When the voltage is supplied to the SSR, the SSR will turn ON. Around point a, where there is virtually no current flow, however,

the SSR will turn OFF. The moment the charge current starts flowing at point b, the SSR will turn ON. At point c, the SSR will turn ON. If the SSR does not turn ON at point b in time, the capacitance will not be fully charged. Therefore, when the SSR turns ON at point c, a high current will flow into the capacitance to supplement the insufficient charge at point b. The same operation is repeated at point d and point e. As a result, the current flow into the SSR is not stable. To solve this problem, a bleeder resistor can be connected in parallel to the power supply so that a current will always flow into the bleeder resistance, thus keeping the SSR turned ON.

Bleeder Resistor Values

100 VAC	5 to 10 kΩ	3 W
200 VAC	5 to 10 kΩ	15 W

Switching Power Supply and Bleeder Resistance

Q24 What are the ideal pattern widths and pitches on a PCB?

The required pattern widths and pitches vary with a the operating conditions, such as the PCB materials and ambient temperature. An example of design standards is provided below.

Conductor Pattern Width and Thickness

A standard copper foil is 35 or 70 μm thick. The width of the foil is determined by the carry current and permissible temperature rise. See the following graph for a simple reference.

Conductor Widths vs. Permissible Currents (IEC Publication 326-3)

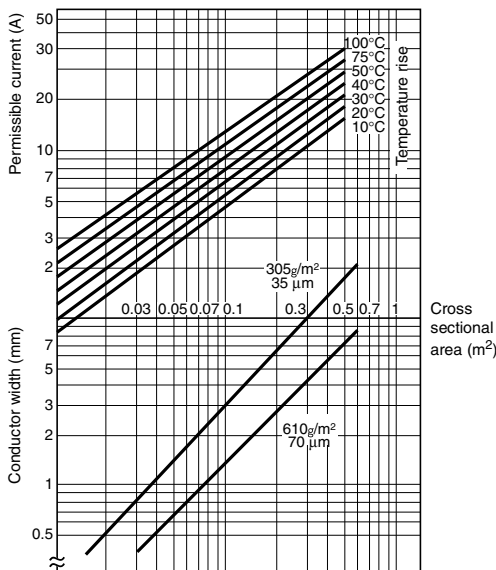

Conductor Pitches

The conductor pitches on a PCB vary with the insulation characteristics and the degree of environmental stress. See the following graph for a standard reference. If the PCB is manufactured in accordance with the Electrical Appliance and Material Control Law or some international safety standards (e.g., UL, CSA, and VDE), however, the requirements of the standards will take precedence. Wider conductor pitches can be used for multi-layer PCBs.

Operating Voltages vs. Conductor Pitches (IEC Publication 326-3)

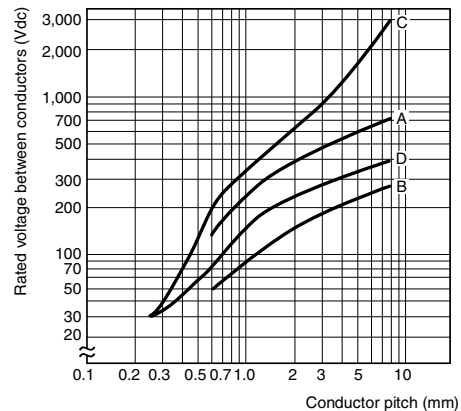

- A: Up to 3,000 mm in altitude with no coating.
- B: Over 3,000 and less than 15,000 mm in altitude with no coating.
- C: Up to 3,000 mm in altitude with coating.
- D: Over 3,000 mm in altitude with coating.

PCB, Pattern Width, and Pattern Pitch

■ Q25. How much thermal resistance is required in the heat sink? What is the thermal resistance of the SSR?

Thermal Resistance of Heat Sinks

- Y92B-A100 = 1.63°C/W
- A150N = 1.37°C/W
- Y92B-N50 = 2.8°C/W
- N100 = 1.63°C/W
- N150 = 1.38°C/W
- Y92B-P50 = 1.67°C/W
- P100 = 1.01°C/W
- P150 = 0.63°C/W
- P200 = 0.43°C/W
- P250 = 0.36°C/W

Note Values indicate the degree of resistance to heat. The smaller the value is, the better the heat conductivity will be. It is normally expressed using °C/W units, i.e., the temperature rise per watt.

Thermal Resistance Rth of SSRs (with Junctions on the Back)

- G3NA-205B = 3.22°C/W
- 210B = 2.62°C/W
- 220B = 1.99°C/W
- 240B = 0.45°C/W
- G3NE-205T = 2.72°C/W
- 210T = 2.12°C/W
- 220T = 2.22°C/W
- G3PB-215B-3H-VD = 1.05°C/W
- 225B-3H-VD = 0.57°C/W
- 235B-3H-VD = 0.57°C/W
- 245B-3H-VD = 0.57°C/W

Note "Junction" refers to the PN junction of the semiconductor element and is used as a representative point on the element to express temperature.

Heat Sink and Thermal Resistance

■ Q26. Can a panel frame be used in place of heat sink?

Yes, but a steel plate used for standard panels has a lower heat conductivity than an aluminum plate and is thus not suitable to high-current applications. If the steel plate is used in place of a heat sink, check that the continuous current flow is a maximum of 10 A. (For details, refer to the SSR's datasheet.)

See the following table for heat radiation for aluminum plates.

Approximate values for heat conductivity (at room temperature):

SSR model	Carry current	Required aluminum plate size (mm)
G3NE-205T(L)	5 A	Not required
G3NA-205B	5 A	75 × 75 × t3.2
G3NE-210T(L)	10 A	100 × 100 × t2
G3NA-210B	10 A	150 × 150 × t3.2
G3NE-220T(L)	20 A	300 × 300 × t3
G3NA-220B	20 A	200 × 200 × t3.2
G3NA-240B	40 A	300 × 300 × t3.2

Metal type	Heat conductivity W/m°C
Iron-based	20 to 50
Aluminum-based	150 to 220
Pure copper	330
Plastics	0.1 to 1

Copper plates have a higher heat conductivity than aluminum plates, making them an excellent material. They easily corrode, however, and must be protected from corrosion by nickel plating or other method to ensure long-term application. Plastics have poor heat conductivity, making them unsuitable for heat sinks.

Heat Sink

■ Q27. What are the carry current characteristics of the radiator?

See the following data on the G3NE and G3NA.

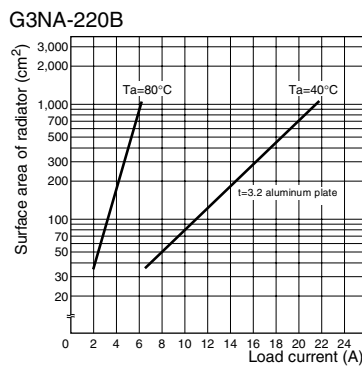
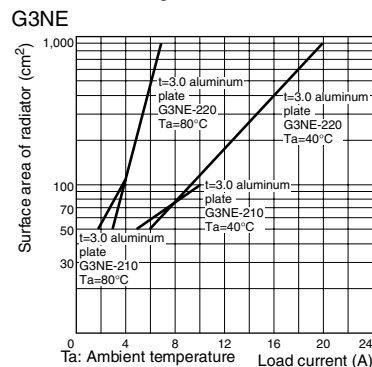

Note: The radiating surface area refers to the total surface area on the front and back of the radiator that is effective for radiating heat. For example, suppose a current of 18 A is passed at a radiating temperature of 40°C. The radiating surface area corresponding to this on the graph is approx. 450 cm². If the radiator is square, the following

calculation gives the minimum length of one of its sides:

$$\sqrt{450(\text{cm}^2)}/2 = 15 \text{ cm}$$

Therefore, it is necessary to use a radiator with sides at least 15 cm long.

Radiator

■ Q28. What is silicon grease?

Special silicon grease is used to aid heat dissipation. The heat conduction of this special compound is five to ten times higher than standard silicon grease.

This special silicon grease is used to fill the space between a heat-radiating part, such as an SSR, and the heat sink to improve the heat conduction of the SSR.

Unless special silicon grease is applied, the generated heat of the SSR will not be radiated properly. As a result, the SSR may break or deteriorate due to overheating.

Available Silicon Grease Products for Heat Dissipation

Toshiba Silicone: YG6111 and YG6240

TORAY Silicone: SC102

Shin-Etsu Silicones: G746

Silicon Grease

■ Q29. What output configuration is suitable when the SSR is used in combination with a temperature controller?

Use an SSR in combination with a temperature controller with a voltage output.

Temperature Controller

■ Q30. What precautions are necessary when driving a number of SSRs with temperature outputs?

Refer to the next page for the number of SSRs that can be connected to a temperature controller.

Interface SSRs will be required to drive more SSRs. With SSRs, leakage currents can cause reset failures. If this is a problem, use the G3RZ, which has a small leakage current.

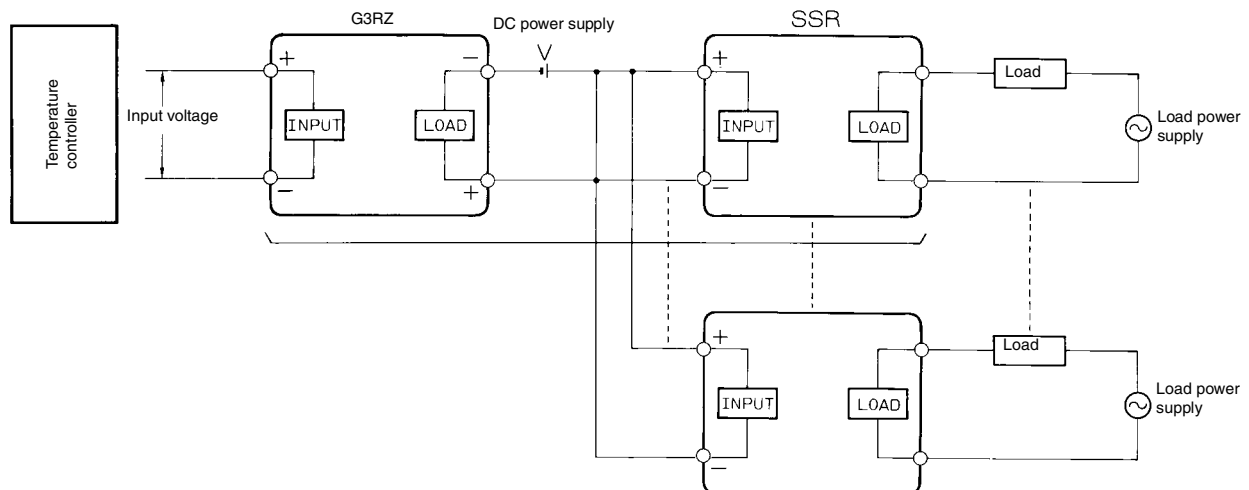

Examples of Connections between Temperature Controllers and SSRs

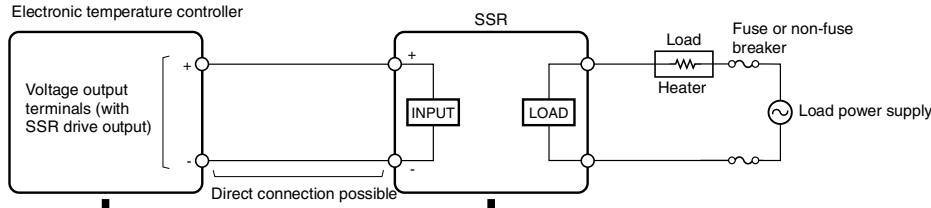

Temperature Controller with 12-VDC output at 40 mA

Temperature Controller with 12-VDC output at 20/21 mA

Possible number of SSR connected in series	G3PB (single phase)	
	Rated voltage input	Image
5	240 VAC; 15, 25, 35, or 45 A	
3	12 to 24 VDC	
Compact and ultra-slim models with a built-in heat sink.		
4	G3PB (3 phase)	
	240/400 VAC; 15, 25, 35, or 45 A	
2	12 to 24 VDC	
Three-phase control with a built-in heat sink.		
5	G3PA	
	240 VAC; 10, 20, 40, or 60 A 400 VAC; 20 or 30 A	
3	5 to 24 VDC	
Compact and slim models with a built-in heat sink.		
5	G3NA	
	240 VAC; 5, 10, 20, or 40 A 480 VAC; 10, 20, or 40 A	
3	5 to 24 VDC	
Standard model with screw terminals		
2	G3NE	
	240 VAC; 5, 10, or 20 A	
1	12 VDC	
Compact, low-cost model with tab terminals		
8	G3NH	
	440 VAC; 75 or 150 A	
4	5 to 24 VDC	
High-power heater control		

Possible Number of SSRs Connected in Series
 A: Max. load current of the SSR-driving voltage output of each temperature controller
 B: Input current of SSRs.
 A/B = Possible Number of SSRs

Temperature Controller and Leakage Current

■ Q31. Is it possible to protect the motor with an SSR and mechanical thermal?

Yes, it is.

If the inrush current resistance of the SSR does not match the protective characteristics of the thermal, however, the SSR may be destroyed by overcurrent within a short period. The period is so short that the motor will not burn out.

In this case, a high-speed breaking fuse can be used to protect the SSR.

Recommended thermal relays with harmonized protection are listed for the G3J, which is an SSR for three-phase motors to which a thermal relay can be mounted.

Thermal

■ Q32. What precautions are necessary for forward/reverse operation of the single-phase motor?

Refer the following table for the protection of capacitor motors driven by SSRs.

Single-phase 100 V	Load current of recommended SSR	Protection of motor in forward/reverse operation	
		R	L
25 W	AC 2 to 3 A	R = 6 Ω, 10 W	Choke coil
40 W			
60 W	AC 5 A	R = 4 Ω, 20 W	
90 W		R = 3 Ω, 40 to 50 W	

Single-phase 200 V	Load current of recommended SSR	Protection of motor in forward/reverse operation	
		R	L
25 W	AC 2 to 3 A	R = 12 Ω, 10 W	Choke coil
40 W			
60 W	AC 5 A	R = 12 Ω, 20 W	
90 W		R = 8 Ω, 40 W	

Precautions for Forward/Reverse Operation

- In the following circuit, if SSR1 and SSR2 are turned ON simultaneously, the discharge current, *i*, of the capacitor may damage the SSRs. Therefore, a minimum 30-ms time lag is required to switch between SSR1 and SSR2. If the malfunction of the SSRs is possible due to external noise or the counter-electromotive force of the motor, connect L or r in series with either SSR1 or SSR2 whichever is less frequently use. A CR absorber (consisting of 0.1-μF capacitor withstanding 630 V and 22-Ω resistor withstanding 2 W) can be connected in parallel to each SSR so that the malfunctioning of the SSRs will be suppressed.

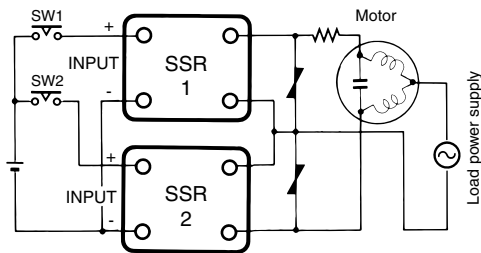

- When the motor is in forward/reverse operation, a voltage that is twice as high as the power supply voltage may be imposed on an SSR that is OFF due to the LC resonance of the motor. OMRON's PCB SSR product ranges cover a maximum of 200-VAC. Therefore, SSRs cannot be used to control motors in forward/reverse operation at 200 VAC in some cases. Before starting the forward/reverse operation of the motor at 200 VAC, measure the voltage that is imposed on the SSR turned OFF and make sure that the SSRs are operable.

G32-OG1 Choke Coil

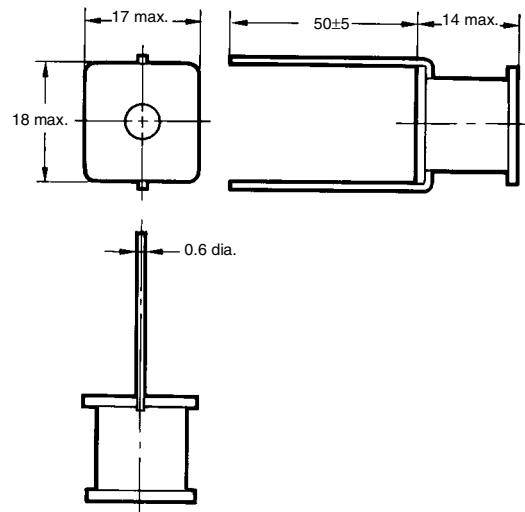

Forward/Reverse Operation

■ Q33. Is it possible to use a three-phase SSR to turn three single-phase circuits ON and OFF?

Three output circuits of the G3J single-function model and those of the G3PB are all separated from each other. Therefore, the output phases can be connected to independent circuits.

Do not use the G3J-S or G3J-T for single-phase circuits, or otherwise the start/stop function will not operate normally.

Configuration

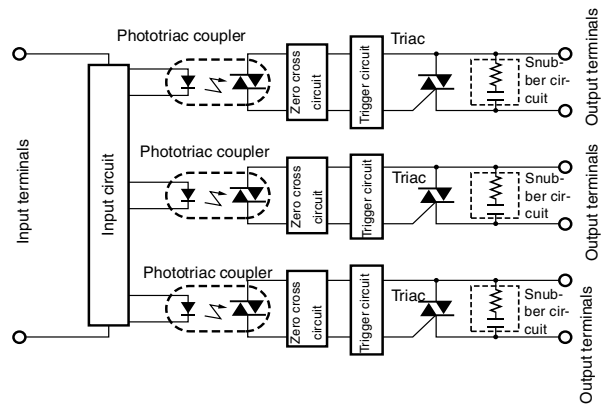

Three-phase SSR

■ Q34. Why is a time lag required between the forward operation and reverse operation of a three-phase motor?

The forward or reverse operation of a three-phase motor is selected by switching two phases. If the SSR for the forward operation of the motor turns ON simultaneously with that for the reverse operation of the motor, a phase short circuit results through the SSRs, thus destroying the SSRs. The reset time of the SSRs fluctuates within a maximum of a half cycle. Therefore, if the forward operation and reverse operation of the motor are

switched quickly, both SSRs may turn ON at the same time destroying them.

When either one of the SSRs is turned OFF, the motor will generate counter-electromotive force, which easily causes the SSRs to malfunction. To prevent this, a longer time lag (at least 30 ms) will be required to switch between the forward and reverse operation of the motor.

Time Lag and Forward/Reverse Operation

■ Q35. Does an SSR have a mounting direction?

An SSR consists of semiconductor elements. Therefore, unlike mechanical relays that incorporate movable parts, gravity changes have no influence on the characteristics of the SSR.

Changes in the heat radiation of an SSR may, however, limit the carry current of the SSR.

An SSR should be mounted vertically. If the SSR has to be mounted horizontally, check with the SSR's datasheet. If there is no data available for the SSR, use with a load current at least 30% lower than the rated load current.

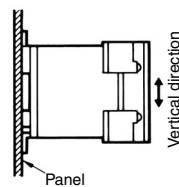
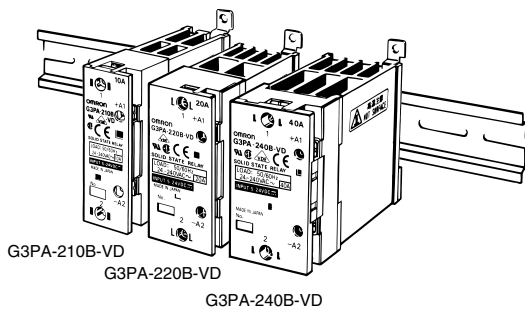

Vertical mounting
Mount the SSR vertically.

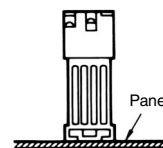

Flat Mounting
The SSR may be mounted on a flat surface, provided that the load current applied is 30% lower than the rated load current.

Mounting Direction

■ Q36. What precautions are required for high-density mounting or gang mounting?

In the case of high-density or gang mounting of SSRs, check the relevant data in the SSR datasheet. If there is no data, check that the load current applied is 70% of the rated load current. A 100% load current can be applied if groups of three SSRs are mounted in a single row with a space as wide as a single SSR between adjacent groups.

If the SSRs are mounted in two or more rows, it is necessary to confirm the temperature rise of the SSR separately.

With side-by-side high-density or gang mounting of SSRs with heat sinks, reduce the load current to 80% of the rated load current.

Refer to the SSR's datasheet for details.

G3PA

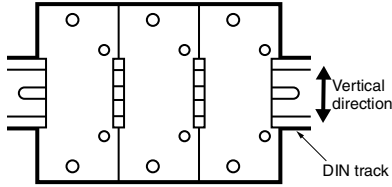

Do not mount more than a group of three Units closely together without providing a 10-mm space to the next group.

G3PB

Characteristic Data

High-density or Gang Mounting (3 or 8 Units)

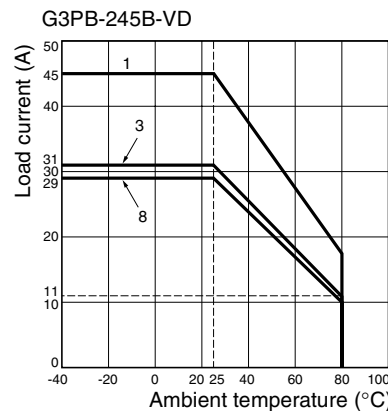
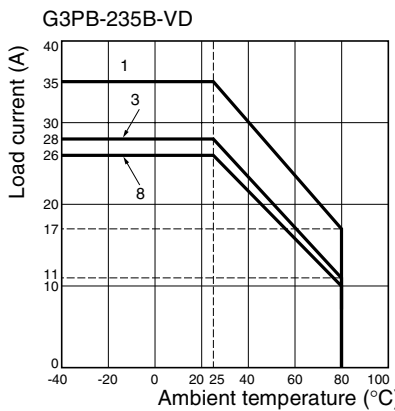
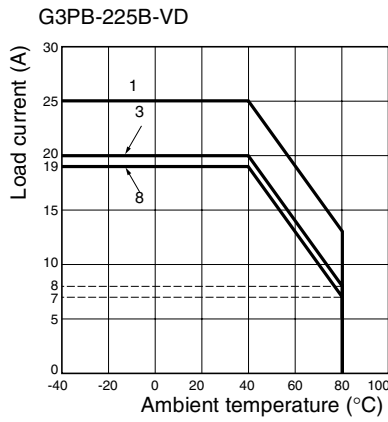
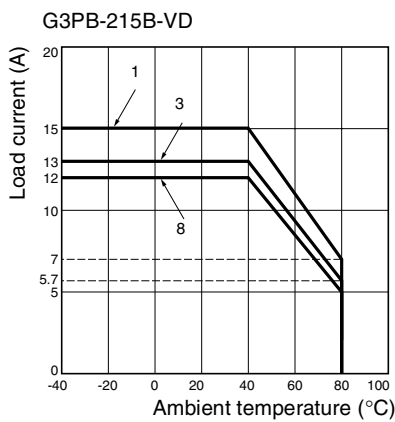

Example of high-density or gang mounting

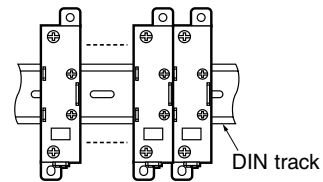

G3TB

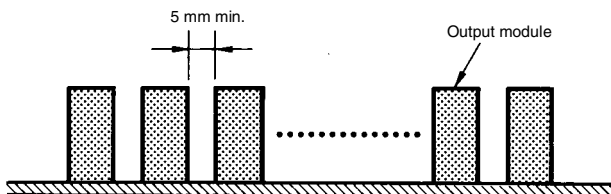

Close-mounting of Output Modules
Provide a minimum space of 5 mm between adjacent SSRs. A load of 3 A can be switched with a maximum of 16 points.

G3TA

A single load current can be switched by each G3TA Unit, if up to four G3TA Units are high-density mounted.

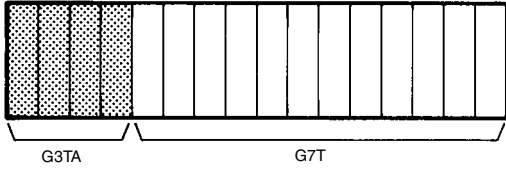

A single load current can be switched by each G3TA Unit, provided that there is a single G3TA Unit between adjacent G3T Units.

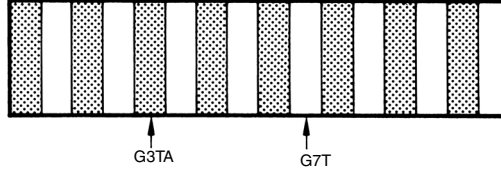

G3M

Characteristic Data

Load Currents Vs. Rated Ambient Temperatures (High-density or Gang Mounting)

G3M-205 Series (5A Load)

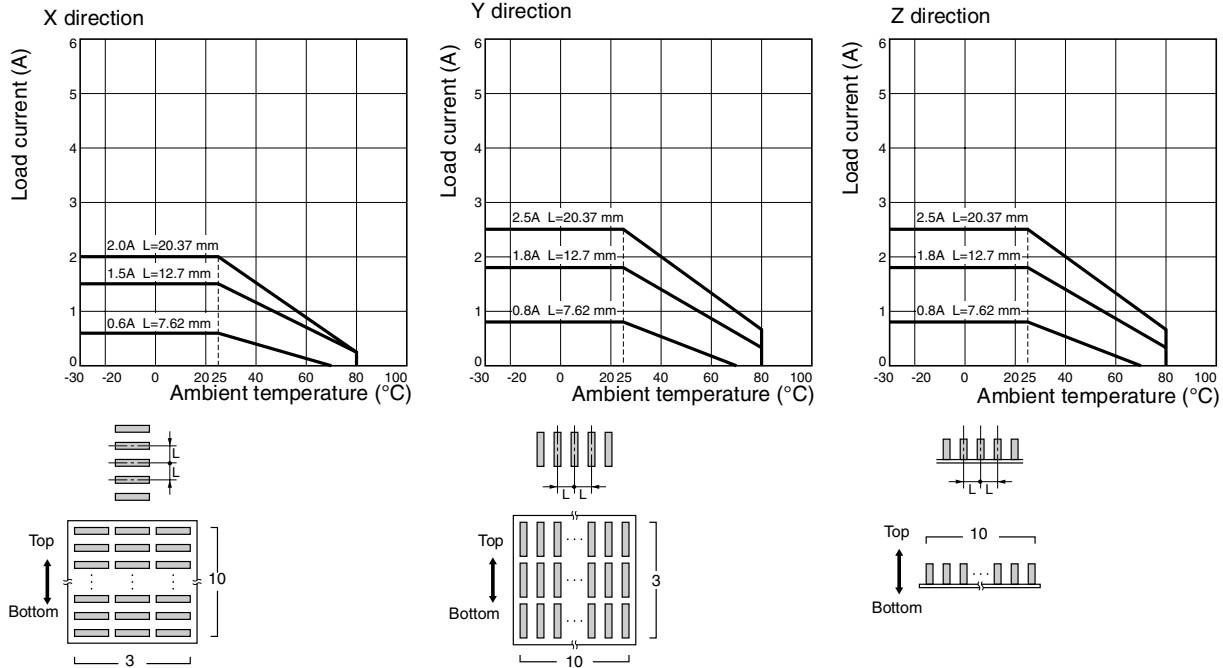

As shown in the above illustrations, 30 Units are soldered on each PCB with a current continuously applied.

High-density or Gang Mounting

■ Q37. What is the non-repetitive inrush current?

The datasheet of an SSR gives the non-repetitive inrush current of the SSR. The concept of the non-repetitive inrush current of an SSR is the same as an absolute maximum rating of an element. Once the inrush current exceeds the level of the non-repetitive inrush current, the SSR will be destroyed. Therefore, check that the maximum inrush current of the SSR in usual ON/OFF operation is 1/2 of the non-repetitive inrush current. Unlike mechanical relays that may result in contact abrasion, the SSR will provide good performance as long as the actual inrush current is a maximum of 1/2 of the non-repetitive inrush current. If the SSR is in continuous ON/OFF operation and a current exceeding the rated value flows frequently, however, the SSR may overheat and a malfunction may result. Check that the SSR is operated with no overheating. Roughly speaking, inrush currents that are less than the non-repetitive inrush current and greater than the repetitive inrush current can be withstood once or twice a day (e.g., this

level of inrush current can be withstood in cases where power is supplied to devices once a day).

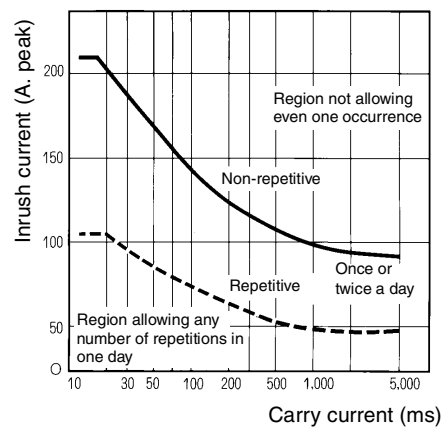

Non-repetitive Inrush Current

Q38. What kind of failure do SSRs have most frequently?

OMRON's data indicates that most failures are caused by over-voltage or overcurrent as a result of the short-circuiting of SSRs.

This data is based on SSR output conditions, which include those resulting from the open or short circuit failures on the input side.

	Failure	Load condition
Input	Short	Does not turn ON.
	Open	Does not turn ON.
Output	Output triac short circuit (80% of failures)	Does not turn OFF.
	Output triac open circuit (20% of failures)	Does not turn ON.

Failure

Q39. What will happen if the load voltage exceeds the upper limit?

OMRON's G3NA, G3NE, and G3PA SSRs, which have a built-in varistor, have a rated load voltage of 264 VAC. These SSRs withstand a maximum of 264 VAC. The built-in varistor operates when the load voltage in actual operation exceeds around 400 VAC and the varistor will be destroyed.

OMRON's G3M or G3CN or G3F SSR does not incorporate a varistor. These SSRs with 200-VAC output withstand a maximum of 264 VAC. The output triac of the SSR in actual operation will be destroyed due to an overvoltage of approximately 600 VAC, provided that the AC is a sine wave current with no distortion or noise.

For an ordinary power supply, there will be an increase in the failure rate of the SSR if the load voltage exceeds 264 VAC.

Overvoltage

Q40. Is it possible to replace a defective part in an SSR?

It is possible to replace the power elements of the G3PX, G3PA, and G3NH. No parts of any other OMRON's SSR are replaceable because the SSR is sealed with plastic resin.

Parts Replacement

Q41. How can we use a multimeter to check if the SSR is ON or OFF?

The resistance of the load terminals of the SSR does not make clear changes when the input turns ON and OFF.

Connect a dummy load to the output terminals and check the voltage of the load terminals with the input ON and OFF. The output voltage will be close to the load power supply voltage with the SSR turned OFF. The voltage will drop to approximately 1 V with the SSR turned ON. This is more clearly checked if the dummy load is a lamp with an output of about 100 W.

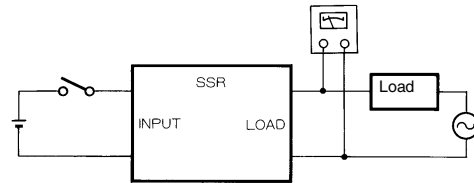

Multimeter Check

Q42. Are there any methods to check whether an old SSR works or not?

Yes, there is.

1. Look at the lot number first.

Lot Numbers
1 2 3 8 E □

Indicates year of production (1998).
Indicates month of production (March); October, November, and December are indicated by X, Y, and Z respectively.
Indicates date of production (12)

2. If the SSR is two years old or less, the SSR will not need any checks in particular.
3. If the SSR is more than two years old, check the following items. The SSR will be usable if these items are okay.
Input operating voltage
Reset voltage
Output ON voltage drop
4. It is recommended not to use the SSR if it is five years old or older.

Lot Number

Q43. Why can MOS FET relays be used for both AC and DC loads?

With power MOS FET relays, because 2 MOS FET relays are connected in series in the way shown on the right, the load power supply can be connected in either direction. Also, because power MOS FET elements have a high dielectric strength, they can be used for AC loads, where the polarity changes every cycle.

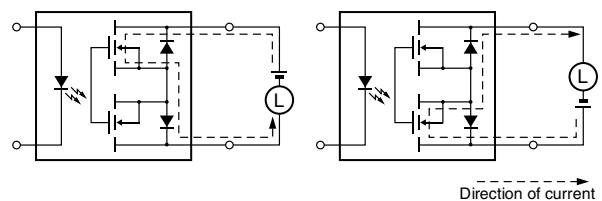

MOS FET Relays

■ Q44. What are the differences between SSRs and power MOS FET relays?

Number 1: There are SSRs for DC loads and SSRs for AC loads.

SSR for DC Loads (e.g., G3SD)

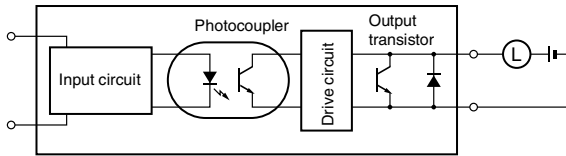

SSR for AC Loads (e.g., G3H)

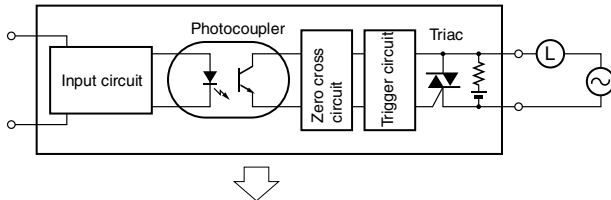

Power MOS FET relays can be used for both DC loads and AC loads.

Number 2: The leakage current for power MOS FET relays is small compared to that for SSRs.

SSRs

The lamp (see below) is faintly light by the leakage current. A bleeder resistance is added to prevent this. With SSRs, a snubber circuit is required to protect the output element.

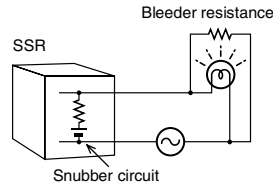

Power MOS FET Relays

The leakage current is very small (10 μ A max.) and so the lamp does not light. This is because a snubber circuit is not required to protect the MOS FET output element. A varistor is used to protect the MOS FET.

Power MOS FET relay

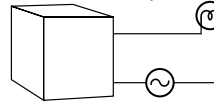

A bleeder resistance is not required and so circuits can be simplified and production costs reduced.

MOS FET Relays

■ Q45. What kind of applications can power MOS FET relays be used for?

- Applications where it is not known whether the load connected to the relay is AC or DC.
Example: Alarm output of robot controller.
- Applications with high-frequency switching of loads, such as for solenoid valves, where the relay (e.g., G2R) has to be replaced frequently.
Power MOS FET relays have a longer lifetime than other relays and so the replacement frequency is less.
The terminals of the G3RZ are compatible with those of the G2R-1A-S and so these models can be exchanged.

Note Confirm the input voltage, polarity, and output capacity before application.

- Applications with high-voltage DC loads.
In order to switch a 125-VDC, 1-A load with a relay, an MM2XP or equivalent is required. With the G3RZ power MOS FET relay, however, switching at this size is possible.
- Applications where SSRs are used with a bleeder resistance.
The leakage current for power MOS FET relays is very small (10 μ A max.) and so a bleeder resistance is not required.

MOS FET Relays

6 SSR Troubleshooting Flowcharts

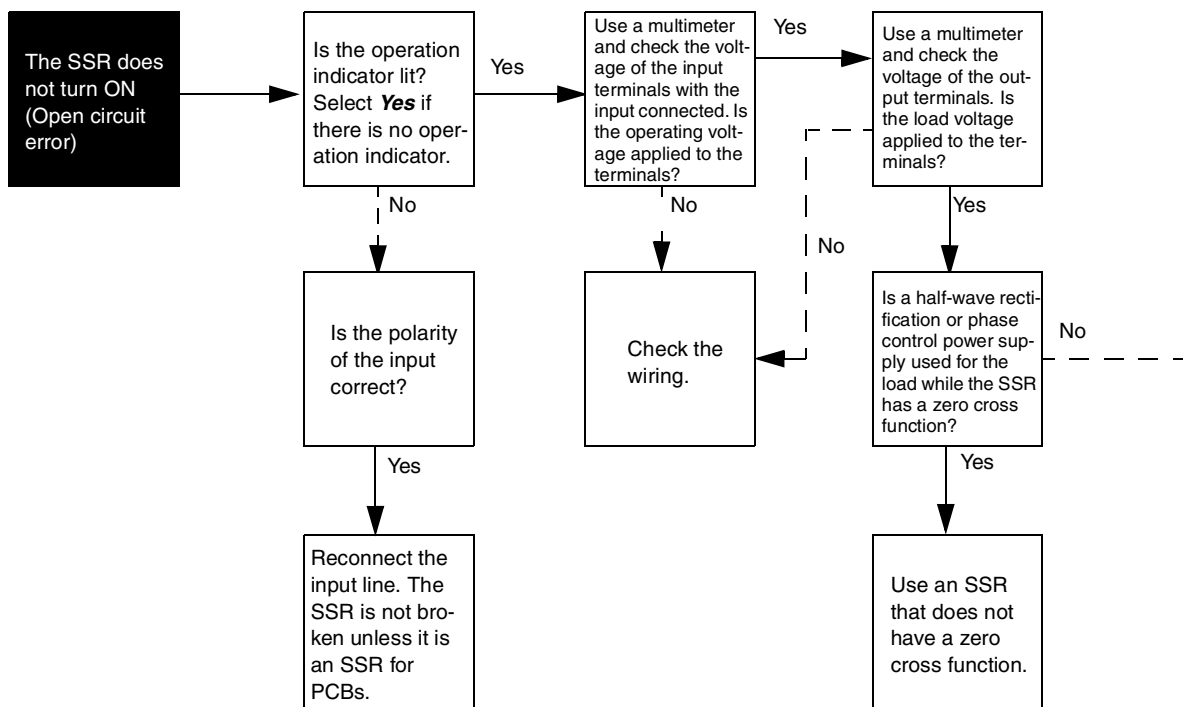
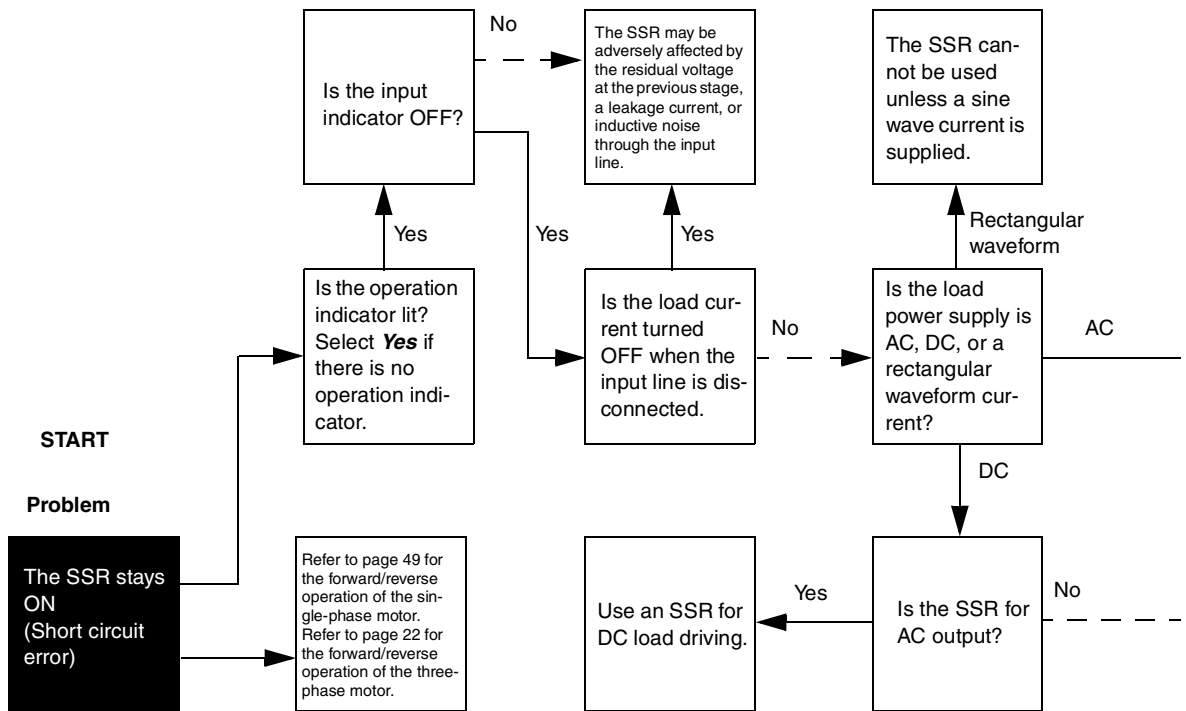

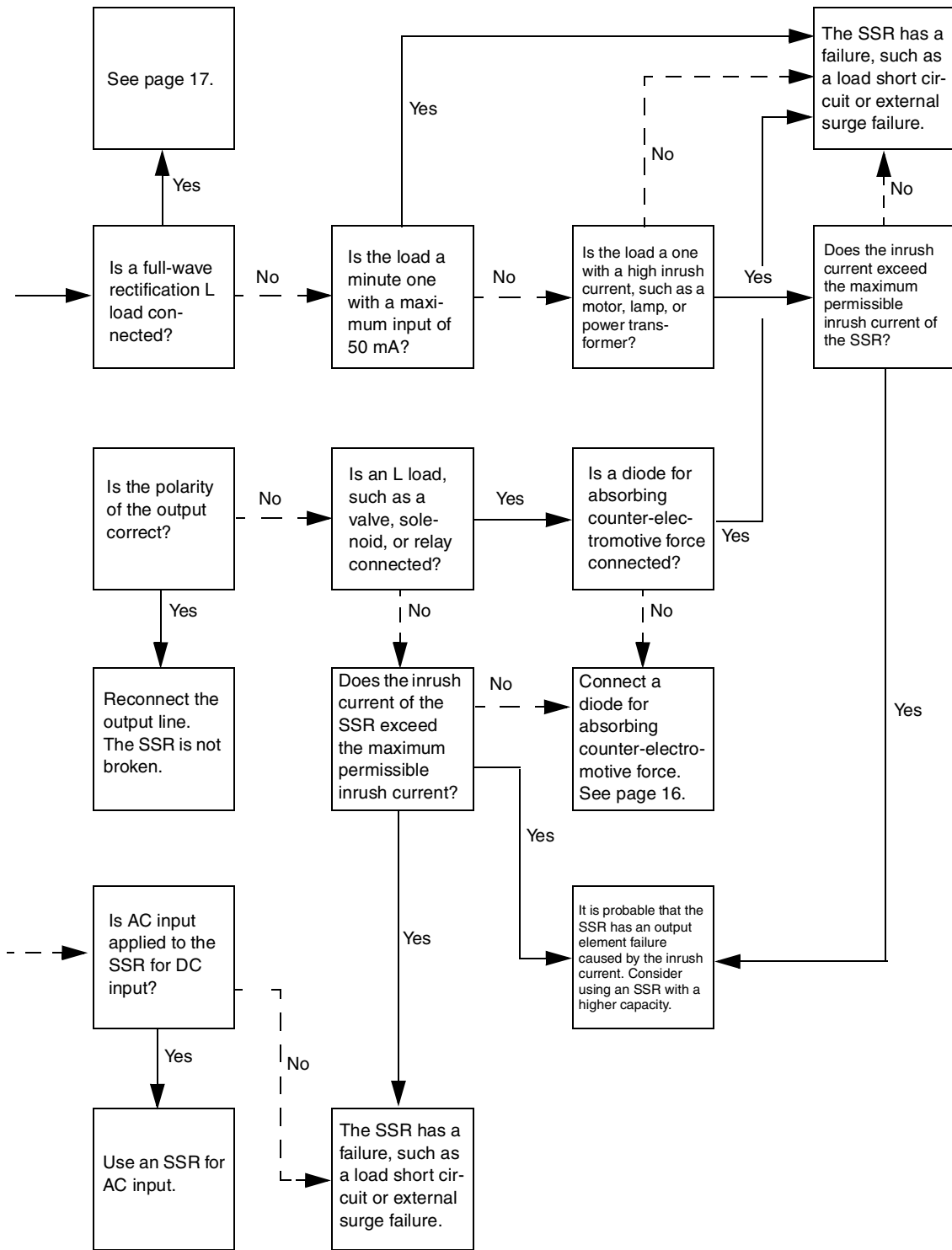

Index

B

bleeder resistance, 44, 45
bleeder resistor, 44

C

carry current, 46
commutation dv/dt , 40
configuration of SSRs, 8
control of SSRs, 9
counter-electromotive force, 41

D

depression-type relays, 40
designing SSR circuits, 14
dielectric strength, 37
 dv/dt , 39

E

electromagnetic relay (EMR), 8
enhancement-type relays, 40

F

fail-safe concept, 27
failure, 53
failure rate, 37
failures, 53
forward/reverse operation, 49, 50
forward/reverse operation precautions, 49
fuse and I^2t , 42

G

gang mounting precautions, 51

H

heat radiation designing, 28
heat sinks, 46
high-density mounting precautions, 51
high-density or gang mounting, 52

hybrid SSR, 40

I

I^2t , 42
input circuit, 14

L

leakage current, 40, 42, 48
leakage current and load voltage, 42
life expectancy, 37
load power supply, 21
lot number, 53

M

mechanical relays, 8
micro, 44
micro-loads, 44
minimum load current, 44
model legend, 41
MOS, 53, 54
MOS FET relay, 44
MOS FET relays, 9, 53, 54
mounting direction, 50
multimeter check, 53

N

negative power supply, 43
non-repetitive inrush current, 52
normally closed contacts, 40

O

operating time, 42
output circuit, 16
overvoltage, 53

P

panel mounting, 32
parallel connections, 43
parts replacement, 53

pattern pitch, 45
pattern width, 45
PCB-mounting SSR, 35
PCBs, 45
photocoupler, 38
phototriac, 38
power factor, 43
precautions, 34

R

radiator, 46
recommended loads, 41
reliability test, 37

S

self-arc suppressing, 39
series connections, 43
silicon grease, 47
snubber, 39
snubber circuits, 40
soft start function, 40, 41
SSR classifications, 11
SSR glossary, 12
static dv/dt , 40
switching power supply, 45

T

temperature controller, 47, 48
thermal, 49
thermal resistance, 46
three-phase SSR, 50
thyristors, 39
time lag, 50
triacs, 39
troubleshooting, 55

Z

zero cross, 38
zero cross function, 38



OMRON ELECTRONICS LLC

1 Commerce Drive
Schaumburg, IL 60173 USA
800.55.OMRON (66766)

OMRON CANADA, INC.

885 Milner Avenue
Scarborough, Ontario M1B 5V8
416.286.6465

OMRON ON-LINE

Global - <http://www.omron.com>
USA - <http://www.omron.com/oei>
Canada - <http://www.omron.com/oci>

24 HOUR FAX ON DEMAND

USA - 847.843.1963
Canada - 788.599.4264

For Distributor Locations or Product Information, Call:

800.55.OMRON or 847.843.7900

UNITED STATES REGIONAL SALES OFFICES

Northeast	Boston, MA	508.303.8880
East	Philadelphia, PA	610.524.1897
Southeast	Atlanta, GA	770.798.6780
Central	Cincinnati, OH	513.469.6766
Midwest	Chicago, IL	847.843.7910
Southwest	Dallas, TX	972.871.2166
West	Los Angeles, CA	714.621.3455

CANADA REGIONAL SALES OFFICES

Ontario	Toronto	416.286.6465
	Kitchener	519.896.1144
	Kingston	613.376.3968
Quebec	Montreal	514.636.6676
	Ste-Foy	418.864.7378
British Columbia	Vancouver	604.522.8855
Alberta	Edmonton	403.440.0818
	Calgary	403.257.3095

BRAZIL SALES OFFICE

Sao Paulo 55.11.5564.6488

ARGENTINA SALES OFFICE

Buenos Aires 54.114.787.1129

MEXICO/LATIN AMERICA SALES OFFICE

Florida 954.227.2121